

# DOCUMENTATION

## TRANSMITTER ELECTRONICS

**9.5027.91.241**

Dok.-Nr. 1043.e KI 34 10/2001

**NMEA 183 V 2.0**

## TABLE OF CONTENTS

Page

1. GENERAL INFORMATION .....	3
2. SERIAL WIND INTERFACE .....	3
3. ERROR IDENTIFICATION.....	4
4. SERIAL OUTPUT: (RS 422) LED-DISPLAY .....	4
5. RS 422 NMEA 0183 V 2.0 DATA INTERFACE .....	6
Position of the DIP Switch on the Multicom Assembly .....	10
Table 1. Parameters to set the Serial Interface .....	11
Supplementary Information .....	12
APPENDIX: TECHNICAL DATAS.....	13

## **1. GENERAL INFORMATION**

The transmitter electronics essentially consists of the following components:

The transmitter electronics with

- Power Supply
- CPU with Wind-Interface
- RS 422 Interface for the LED Display
- Analgo Input Interface
- RS 422 NMEA Data Interface  
for NACOS and CUSTOMER
- Barometric air pressure sensor and interface – option
- Analogue Output Interface
  - 4-20 mA - instant. wind speed
  - 4-20 mA - instant. Wind direction
  - 4-20 mA - 2 min.-mean value wind speed
  - 4-20 mA - 2 Min.-mean value wind direction

The transmitter electronics connects the different components of the measurement unit with each other over a measurement system and processes the following parameters:

- Wind Speed
- Wind Direction

## **2. SERIAL WIND INTERFACE**

The digital input wind interface adapts the different data transmitters to the bus system. The digital input values are transmitted to the wind interface card and, from there, are called up once a second by the processor from a buffer storage.

Either a separate data transmitter for wind speed and for wind direction or a combined wind transmitter can be connected to detect ground level, horizontal components of the wind vector in a measuring range between 0.3 and 50 m/s.

When the distance between the wind transmitter and the control electronics is not great, the electronics system supplies the wind transmitter (or wind transmitters) together with its heating system with power. At greater distances (over 50 m) between the wind transmitter and the control electronics, there is a drop in voltage on the lines which leads to a reduced heating power. In this case, a terminal box with a heating transformer should be set up in the vicinity of the wind transmitter.

### **3. ERROR IDENTIFICATION**

The unit can identify hardware and software errors. It can also restart the program (LED "WD" lights up on the CPU) with the help of a RESET-logic (Watchdog) if the program run has malfunctioned. During normal operation, the LED "WD" on the CPU is off.

The output signals of the wind speed transmitter are raised by the switching voltage of one diode (approx. 0.7 V) against reference point ground (life zero); this makes it possible to detect defects in the transmitter or in the cable. The corresponding error message appears on the outputs and displays.

Malfunctions in the program run are detected with the aid of a triggerable RESET logic (Watchdog). The CPU is reset and all registers and memories are re-initialized.

### **4. SERIAL OUTPUT: (RS 422) LED-DISPLAY**

The data telegram of the acquired data is available at the serial output of the electronics for wind speed and wind direction in ASCII format for transmission to the LED display. The setting of the interface is programmed and cannot be changed by the user:

The following parameters are set:

serial, asynchronous  
simplex

Baud rate	:	1200	bit/s
Data length	:	7	bit
Parity	:	even	
Start-Bit	:	1	bit
Stop-Bit:	:	1	bit

4-pole Tuchel plug connection

Pin-No.

1	Tx+
2	TX-
3	GND
4	shield (protective conductor)

## SERIAL OUTPUT TELEGRAM FOR LED-DISPLAY

The data telegram has the following format:

No.	Character	Key
1	\$	Startcharacter
2 - 5	XX.X	Wind speed, (instan).unit of meas. m/s
6		Separator (Space)
7...9	xxx	Winddirection (instan.) unit of meas. Grad
10	*	Checksum follows
11	H	Checksum High-Byte
12	L	Checksum Low-Byte
13	CR	Carriage Return
14	LF	Line Feed

- All characters are displayed in ASCII code.
- Leading zeros in the measured values are replaced by spaces (20 HEX).
- Carriage return and line feed are carried out separately with CR (OD hex) and LF (OA hex).
- Every data telegram starts with STX (02 hex)
- Positive signs are replaced by spaces (20 hex).
- Erroneous measured values are masked with F's.
- Signs for erroneous measured values are replaced by spaces (20 hex).
- The individual measured values are separated by a space (20 hex).
- The checksum is the XOR function from byte 2 to byte 9 inclusive.

## 5. **RS 422 NMEA 0183 V 2.0 DATA INTERFACE**

### NACOS and CUSTOMER INTERFACE

- Type of Interface  
simplex, serial, asynchronous (RS 422)
- Type of Leads  
5 pole Tucher plug connection NACOS  
7 pole Tucher plug connection CUSTOMER

#### Pin-No

1	TX+
2	TX-
3	UND signal ground
4	PGND non-fused earth contact shield

- Transmitting cycle  
The transmitter electronics outputs a data telegram once a second.
- Transmission Parameters  
The transmission parameters can be set individually for each channel of the interface. To do this, unplug the instrument from the supply voltage and pull the multicom interface out of the transmission electronics.

The number of transmitted data bits is set to 8.

Parity can now be selected, either "Even Parity" or "No Parity".

Baud rates are adjustable and have been set at the factory to 4800 bit/s.

## DATA TELEGRAM NMEA 0183 V2.0

For Interface ATLAS-ELECTRONICS

Interface 1: NACOS  
Interface 2: CUSTOMER

Four data telegrams are transmitted over each interface. The time interval between the individual data telegrams is 50 ms whereby both interfaces must be set to the same baud rates.

- |                  |             |
|------------------|-------------|
| 1. Data telegram | Humidity    |
| 2. Data telegram | Pressure    |
| 3. Data telegram | Temperature |
| 4. Data telegram | Wind        |

### Data Telegram Humidity

No.	Character	Key
1	\$	Start of Text
2 - 6	WIMHU	Weather Instrumentation Humidity
7	,	Separator
8 - 12	xxx.x	Rel. Hum. unit of meas. %
13	,	Separator
14 - 18	xxx.x	Absol. Hum. unit of meas. g/m <sup>3</sup>
19	,	Separator
20 - 24	+xx.x	Dewpoint Temp. unit of meas. °C
25	,	Separator
26	C	unit of meas. °C
27	*	Checkbyte follows
28	H	Checkbyte High
29	L	Checkbyte Low
30	CR	Carriage Return
31	LF	Line Feed

### Data Telegram Pressure

No.	Character	Key
1	\$	Start of Text
2 - 6	WIMMB	Weather Instrumentation Barometer
7	,	Separator
8 - 12	xx.xx	Air Pressure unit of meas.inch o. Mercury
13	,	Separator
14	I	inch o. Mercury
15	,	Separator
16 - 20	x.xxx	Air Pressure unit of meas. Bar
21	,	Separator
22	B	Bar
23	*	Checkbyte follows
24	H	Checkbyte High
25	L	Checkbyte Low
26	CR	Carriage Return
27	LF	Line Feed

### Data Telegram Temperature

No.	Character	Key
1	\$	Start of Text
2 - 6	WIMTA	Weather Instrumentation Air Temperature
7	,	Separator
8 - 12	+xx.x	Air Temp. unit of meas. °C
13	,	Separator
14	C	°C
15	*	Checkbyte follows
16	H	Checkbyte High
17	L	Checkbyte Low
18	CR	Carriage Return
19	LF	Line Feed



## Data Telegram Wind

No.	Character	Key
1	\$	Start of Text
2 - 6	WIMWV	Weather Instrument. Wind Speed and Angle
7	,	Separator
8 - 12	xxx.x	Winddirection unit of meas. Degree
13	,	Separator
14	R	Relative Winddirection
15	,	Separator
16 - 19	xx.x	Windvelocity unit of meas. m/s
20	,	Separator
21	M	m/s
22	,	Separator
23	A	Status V= not valid / A = valid
24	*	Checksum follows
25	H	Checksum High
26	L	Checksum Low
27	CR	Carriage Return
28	LF	Line Feed

All characters are transmitted in ASCII code.

Leading zeros are transmitted.

The formation of the checksum is the XOR function of byte 2 to the character "\*" exclusively.

Erroneous values are replaced by zero fields.

The plus sign is omitted for positive values; it is replaced by a leading zero.

No software and no hardware handshake is possible.

**Position of the DIP Switch on the Multicom Assembly**

**Table 1. Parameters to set the Serial Interface**

Position of the DIP switch on the multicom interface

Switch in Pos. OPEN = 1

Switch in Pos. CLOSED = 0

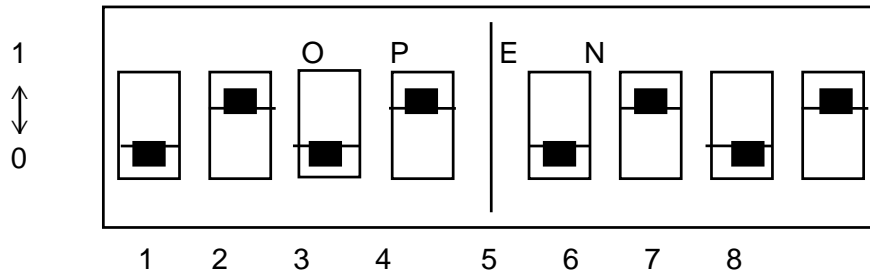

Channel 1

Channel 2

Baudrate	Baudrate	Par.	Baudrate	Par.
19200 Bit/s	0 0 0	X	0 0 0	X
9600 Bit/s	1 0 0	X	1 0 0	X
* 4800 Bit/s	0 1 0	X	0 1 0	X
2400 Bit/s	1 1 0	X	1 1 0	X
1200 Bit/s	0 0 1	X	0 0 1	X
600 Bit/s	1 0 1	X	1 0 1	X
300 Bit/s	0 1 1	X	0 1 1	X
150 Bit/s	1 1 1	X	1 1 1	X
Switch	1 2 3	4	5 6 7	8

Parity: x = 1 no parity  
x = 0 even parity

## Supplementary Information

### Inputs: Windinterface

Wind Speed	:	pulse transmitter	:	0...1052 HZ
		meas. range	:	0,3...50,0 m/s
		resolution	:	0,1 m/s
Wind Direction	:	Code-Transmitter	:	8-bit seriell
		meas. range	:	0...360 Degrees
		resolution	:	2,5 Degrees
Transmitter Power Supply	:	+5 V =		
Heater	:	24 V/ 50 Hz	max. 40 VA	
Connecting cablel	:	LiYCY 12x 0,75 mm <sup>2</sup>		
max. Length	:	for Heating supply		
		from AWS: ca. 50 m		
		with a separate heating transformer:		
		approx. 500 m		

The station has its own transformer which supplies power to heat the transmitter. However, if the transmitter is more than 50 m away from the transmission electronics, then an external heating transformer must be used.

### Analog Outputs:

Wind speed	:	4-20 mA : 0 – 50 m/s instant. value
Wind direction	:	4-20 mA: 0 – 360 <° instant. value
Wind speed	:	4-20 mA : 0 – 50 m/s 2 min.-mean value
Wind direction	:	4-20 mA: 0 – 360 <° 2 Min.-mean value

## APPENDIX: TECHNICAL DATAS

Appendix A:

CPU Card (Mounting Side)

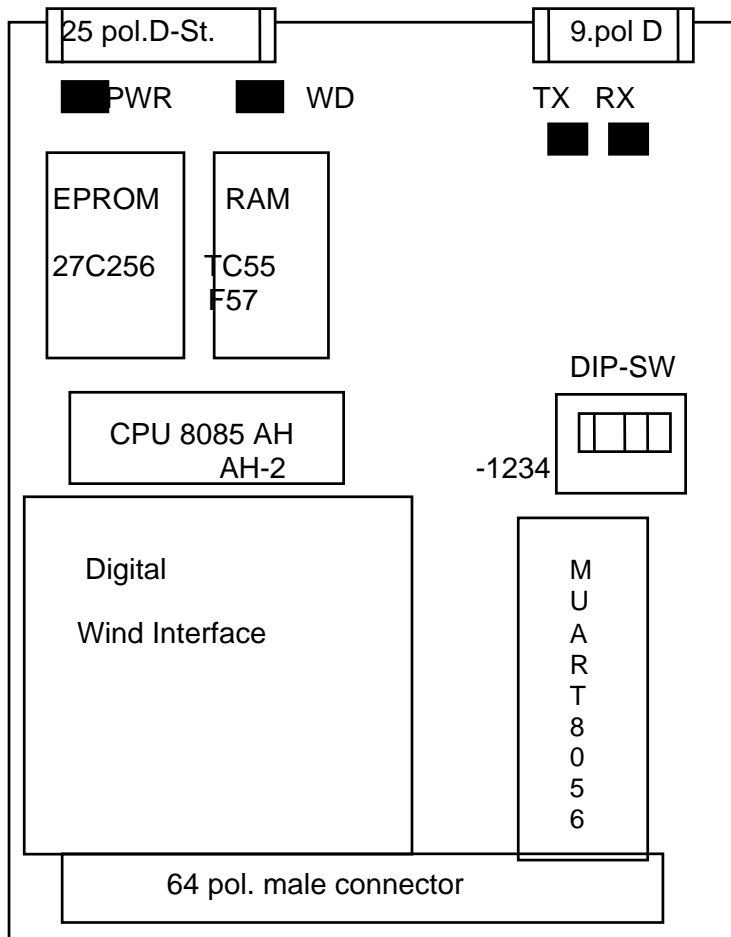

LED WD\* = Watchdog red  
LED PWR = Power on green  
LED TX = Transmitt red  
LED RX = Receive red

Temperature range : 0 ... +45 °C



**ADOLF THIES GmbH & Co. KG**

Hauptstraße 76 37083 Göttingen Germany  
P.O. Box 3536 + 3541 37025 Göttingen  
Phone ++551 79001-0 Fax ++551 79001-65  
www.thiesclima.com info@thiesclima.com



- Alterations reserved -