

Sensor-Interface

Type: Ship

9.3099.00.113

9.3099.01.113

ADOLF THIES GmbH & Co. KG

Hauptstraße 76

Box 3536 + 3541

Phone ++551 79001-0

www.thiesclima.com

37083 Göttingen Germany

37025 Göttingen

Fax ++551 79001-65

info@thiesclima.com

Contents

1	Models available	2
2	Application	3
3	Installation.....	3
3.1	Mechanical Mounting	3
3.2	Electrical Mounting.....	4
3.2.1	Cable Mounting.....	4
4	Mode of Operation	5
4.1	Format of Data Telegram „LED“ via COM3 („mml3“)	5
5	Pin Assignment Operation Interface COM1	6
5.1	Assignment for standard operation	6
5.2	Assignment for a firmware-update	6
6	Operation	7
6.1	Power up message.....	7
6.2	Set of Commands.....	7
6.3	Application and Configuration	8
6.3.1	Adjustment to Telegram Format LED at „COM3“	8
6.3.2	Channel Configuration	8
6.4	Saving the Configuration	9
6.5	Calibration	9
7	Firmware Update	10
8	General Function Remarks	10
9	Connection Diagram (Example).....	10
10	Technical Data.....	12
11	Dimensional Drawing.....	13
12	Accessories (optional)	13
13	EC-Declaration of Conformity	14

Preamble

This instruction manual describes the factory-setting of the sensor interface for application of a certain measuring device configuration.

In case of deviations to the system configuration or customer requirements an additional separate description is delivered along with this standardized instruction manual.

1 Models available

Order-No.	Operating Voltage	Electrical output	Configuration
9.3099.00.113	230V / 50Hz	Online telegram output	Interface pc-board with connection box and power supply
9.3099.01.113	115V / 50-60Hz	Online telegram output	

2 Application

The sensor interface (SENSOR-IF) provides a disturbance-free acquisition and remote transmission of measuring values via a 4/5-wire cable RS232/RS422.

It serves for the acquisition of analogue measuring values. It is used for the direct connection/further processing to a PC or weather display via RS232/RS422.

Fields of application are, for example:

- Addition of systems available by distal measuring sensors, without re-cabling
- Sensor connection to systems (pc/logger) via digital/serial interface.
- Controlling of weather displays for the visualisation of instantaneous values.

The sensor interface pc-board is integrated in a connection box, which serves for the power supply of the pc-board, for the connection of measuring value transmitters and their power supply.

3 Installation



Attention

The sensor interface must be mounted and wired only by a qualified expert, who knows and observes the generalities of technics, and applicable regulations and norms.

The sensor interface must be mounted and wired only in de-energised condition.

The connection box of the sensor interface must be opened only in dry environment.

3.1 Mechanical Mounting

The sensor interface with connection box is designed for wall mounting. For fixing see dimension drawing (chapter 11).

The connection box can be mounted onto a mast, stand support or tube by means of an optional installation kit.

Attention:

The screwed cable glands must point downward.

3.2 Electrical Mounting

For connecting the measuring value transmitters remove the cover by loosening the screws on the front. The terminal clamps are now freely accessible.

Remark
The electrical connection is carried out according to the additional connection diagram of the complete measuring system.

The cables are guided through the screwed cable glands, located in the housing, and are connected to the terminal clamps. Please attend to the cable diameter.

After wiring work is done the nuts of the cable glands and the screws of the cover are to be evenly screwed tightly to the housing.

3.2.1 Cable Mounting

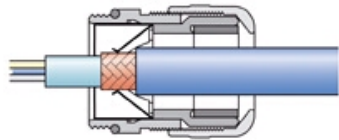
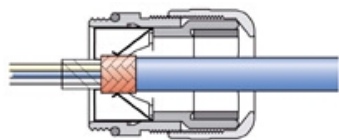
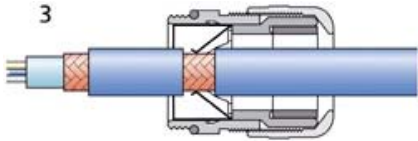
<p>In order to carry out an EMC-compatible installation the cable screen/shielding (except the supply cable, which, in general, is not shielded) is to be connected to the contact spring of the screwed cable gland (see figure).</p> <p>1. With the Standard Contacting (see 1)</p> <ul style="list-style-type: none"> - Strip back the outer sheath and screen (shielding) - Make a round cut in the outer sheath approx. 15 mm along but do not remove the sheath - Guide the cable through the cable gland - Pull off the outer sheath - Pull back the cable until the connection is made between the cable screen and contact spring - Turn shut... and it is ready for use! 	<p style="text-align: center;">1</p> 
<p>2. With thin Wires without an Inner Sheath (see 2)</p> <ul style="list-style-type: none"> - Strip back the outer sheath - Pull back the screen braid approx. 15-20mm over the outer sheath - Insert the cables into the cable gland until the contact is made between the cable screen and contact spring - Turn shutand it is ready for use! 	<p style="text-align: center;">2</p> 
<p>3. When Routing the Cable Screen to another Connection (see 3)</p> <ul style="list-style-type: none"> - Expose the screen braid approx. 10 mm - Guide the cable through the cable gland until the connection is made between the cable screen and contact spring - Turn shut...and it is ready for use! 	<p style="text-align: center;">3</p> 

4 Mode of Operation

The SENSOR-IF acquires the analogue output signals of the wind sensor and processes them within 1s.

For the direct data acquisition by PC without datalogger the automatic telegram output is selected via COM3. In this mode a telegram is output every 1- 2 seconds (depending on the number of measured channels and the interface velocity).

The telegram Wind LED („mml3“) is preset via COM3 by function „max. wind“.

The function „max. wind“ outputs always the wind velocity of the wind sensor, which measures the maximum wind velocity with the respective wind direction.

In case the measuring values of a wind sensor are erroneous, the values of another wind sensor are used. (for ex.: sensor/supply cable defective etc). In order to detect sensor failures, „FF.F FFF“ is output every 60 s for 10 sec!

By connecting an external three-stage pre-selector the function „max. wind“ can be changed.

3- Stage- Pre-Selector

1. stage: contact 1 + 2 open = Function „max. wind“ is active (description see above)
2. stage: contact 1 closed = only wind velocity and wind direction of the first sensor are acquired.
3. stage: contact 2 closed = only wind velocity and wind direction of the second sensor are acquired.

4.1 Format of Data Telegram „LED“ via COM3 („mml3“)

No.	Character	Description	Value	Range
1	STX	Start of Text	Hex 02 4x ASCII	
2...5	XX.X	Instantaneous value of wind velocity	unit m/s	0.0 to 75.0
6		Separator (SPACE)	Hex 20	
7...9	XXX	Instantaneous value of wind direction	unit °	0 to 359
10		Star	Hex 2A	
11...12	XX	Check sum iHEX, bitwise XOR over 2. character to the „*“(exclusive)	Hex-Format	00 to FF
13	CR	Carriage return	Hex 0D	
14	ETX	End of Text	Hex 03	

Example telegram („mml3“):

```
<STX>11.4 180*03<CR><ETX>           in standard case  
<STX>FF.F FFF*0E<CR><ETX>           in error case
```

Remarks to data telegram „mml3“:

- All characters are displayed in ASCII -code.
- The telegram has a constant line length of a total of 14 characters incl.. STX and ETX.
- Leading zeros of the measuring values are replaced by “spaces” (20 HEX).
- All points have fixed position.
- Erroneous measuring values (for ex caused by measuring range overflow) are replaces by one or several F, depending on the position, point inclusive:
for ex. „FF.F“ for an erroneous wind velocity and „FFF“ for a defective or non-connected wind direction transmitter
- The individual measuring values are separated by space character „SPACE“ (20 Hex).
- The baud rate of the operating interface „COM1“ (RS232) is preset to 9600Bd 8N1.
- The baud rate of the online interface „COM3“ (RS422) is set to 4800Bd n81.

5 Pin Assignment Operation Interface COM1

5.1 Assignment for standard operation

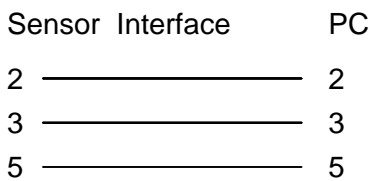

5.2 Assignment for a firmware-update

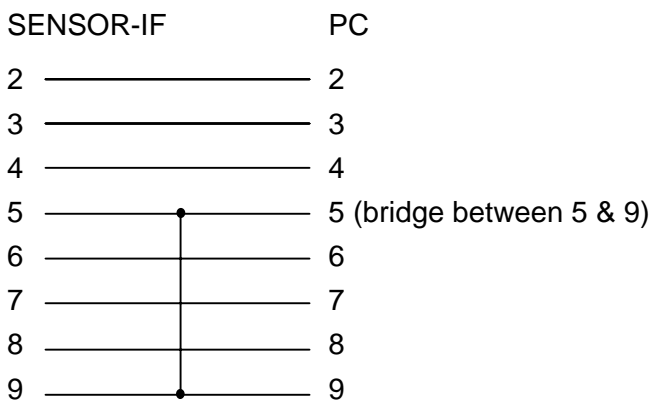

Remark:

In case of busy interface cable, the SENSOR-IF can be kept in reset-mode at the PC by handshake-lines. Therefore, the assignment under 5.1 is compulsory for standard operation.

6 Operation

6.1 Power up message

Connect the Pc with the sensor interface by means of a serial extension cable (1:!), see chapt. 5. Open an adequate terminal program (for ex. TeraTerm or Hyper-Terminal), select the interface and set to the parameters 9600Bd 8N1 (default).

At power-up of the sensor interface the following message is output at the COM1 (RS232 SUB-D):

```
-----  
SENSOR-INTERFACE DL  
Version: 0.48c  
Device: 0704282  
Release: Nov 20 2007  
-----  
Help: <Strg-B>HH<Strg-C>  
-----
```

6.2 Set of Commands

The operation and calibration of the sensor interface is possible only via a rudimental set of commands, and only via the COM1 (RS232 SUB-D). All commands are initiated by <Strg-B> and are terminated by <Strg-C> !

After entering the command „HH“ in the form <Strg-B>HH<Strg-C> the following help is output:

```
List of commands:  
-----  
HH          : this help  
<...>      : optional parameters (no space characters)  
MM|mm<r>    : telegram output with description(MM)/short form(mm), r: autom.  
mmk<2|3>    : autom. telegram only with active channels  
mmh<2|3>    : autom. telegram(HEX), output port 2:COM2 or 3:COM3  
            HEX-telegram: <STX><WERT1> <WERT2> <...>*<CHKSUM><ETX>  
mml<2|3>    : autom. telegram for LED-display, output port 2:COM2 or 3:COM3  
mmo<2|3>    : autom. telegram online + LED, output port 2:COM2 or 3:COM3  
ST<a>       : stops autom. Telegram output (a: on all interfaces)  
KK<CH,FUNC> : Channel- configuration CH:channel(1-14), CH:all|none|d(default), FUNC:0|1  
CI<CH><c|d> : CH: analogue-channel which is calibrated  
            c: calculates Gain and Offset, d: default Gain  
BR<N:BAUD[P]> : N: 1=COM1(SUB-D), 2=COM2(232-KL:11+14), 3=COM3(422-X2)  
            : BAUD: 1=1200, 2=2400, 3=4800, 4=9600, 5=19200  
            : P: 7=7E1 (nur COM3)  
WC<w|r|a>   : w/r saves/reads the configuration  
            a: saves also the automatic telegram output  
XX<v>       : v: version info  
END
```

(Further commands which are not given here, do not matter to the model „type-ship“)

6.3 Application and Configuration

Through <Strg-B>MMr<Strg-C> all shown measuring values are displayed cyclically in clear text. The output stops after entering <Strg-B>ST<Strg-C> or on power-up/down.

Detailed output telegram (only with „MMr“):

└── autom. output (repeat-mode)

```

Instantaneous measuring values:
-----
wind veloc. 1:    8.4 m/s    [1] 31 (20mA) 32 (GND)
Wind direct.1:  120 °      [2] 33 (20mA) 34 (GND)
wind veloc. 2:   15.0 m/s   [3] 65 (20mA) 66 (GND)
Wind direct.2:   50 °      [4] 67 (20mA) 68 (GND)
Live-Counter:   322        internal counter
END

```

└── Terminal connections
channel number

The telegram output „mm“ (<Strg-B>mm<Strg-C>) would respectively look like this:

```

0322  8.4 120 15.0 50*0D

```

```

          1.    2.    3.
    ┌──┐ ┌──┐ ┌──┐ ┌──┐ ┌──┐
0568  8.4 ??? -.- 50*10

```

- 1. Sensor not connected or defective
- 2. Channel masked out
- 3. Check sum (bitwise XOR conjunction from first character to the „*“exclusive)

6.3.1 Adjustment to Telegram Format LED at „COM3“

The baud rate of the „COM3“ is set to 9600Bd 8N1 with : <Strg-B>BR3:38<Strg-C>
The output telegram of the „COM3“ is defined to LED with: <Strg-B>mmI3<Strg-C>.

6.3.2 Channel Configuration

For powering-down the wind velocity measurement 1 the following command is entered:

```
<Strg-B>KK1,0<Strg-C>
```

Response from SESNSOR-IF: channel-config.(IF): 1111

For re-starting please enter the following:

```
<Strg-B>KK1,1<Strg-C>
```

6.4 Saving the Configuration

For saving of a modified configuration permanently (beyond a restart of the „SENSOR-IF“) please enter: <Strg-B>**WCw**<Strg-C>.

Automatic telegram outputs which are temporarily set are not considered there!

If the automatic telegram output shall be retained, as well, please save with:

<Strg-B>**WCa**<Strg-C> .

6.5 Calibration

of the analogue inputs:

1. Set the output telegram „MMr“ (s. chap. 6.3.).
2. the input to be calibrated must be switched on (s. channel configuration chap. 6.3.).
3. connect an adjusted voltage-/power source to the respective terminal
4. Set the source to final value (s. value in brackets with terminal connections)
5. calibrate respective channel through: <strg-B>**CI**<channel number >**c**<strg-C>
6. check the calibration by means of the half-measuring value – if without success, there is the following option:
 - a.) factory-scaling (not calibrated) through: load <strg-B>**CI**<channel-number>**d**<strg-C> and repeat the procedure starting from item 4.
 - b.) Power-off the SENSOR-IF for a short time and start with item 1.
7. Save the new calibration with: <strg-B>**WCw**<strg-C>

Remarks:

Calibration of inputs must be carried out only by an authorised service engineer with respective calibration sources.

The powering-off and re-starting of the sensor interface causes a reset to the last updated calibration; therefore, a saving after every effectively calibrated input is recommendable.

*This is done with: <strg-B>**WCw**<strg-C>*

7 Firmware Update

Firmware updates are to be carried out only by authorized service engineers, as the changing of input sensitivity or scaling of new sensors require an adjustment of the inputs.

The firmware update can be carried out only via the interface COM1 (RS232 SUB-D).

For pin assignment between sensor interface and PC refer to page 6, chapt. 5.2.

For updating the PC software „TI-DOWNLOADER“ is required (only Windows 95/98 or higher).

8 General Function Remarks

Using a standard cable (serial extension) at the COM1 (X15) might result in the fact, that the sensor interface is kept in “RESET”-mode, when the levels (DTR/RTS) are on “LOW” on PC-side (for ex.: no terminal program started). (see page.5, chapt. 4.1)

Corrective: A short break of power supply.

The green LED must flash in standard operation at 0,3 to 0,5 Hz.

The red and the green LED flash alternately.

On re-start of the sensor- IF a power-up message is output via the COM1 also with automatic telegram output (s. page 6, chapt. 5.1). Afterwards, „?“ ... „???.?“ resp. „FF.F FFF“ is output for all measured channels in the first four telegrams.

9 Connection Diagram (Example)

- Standard connection diagram 6198 (see page 11)

Remark:

In case of deviations to the system configuration an additional separate connection diagram is enclosed.

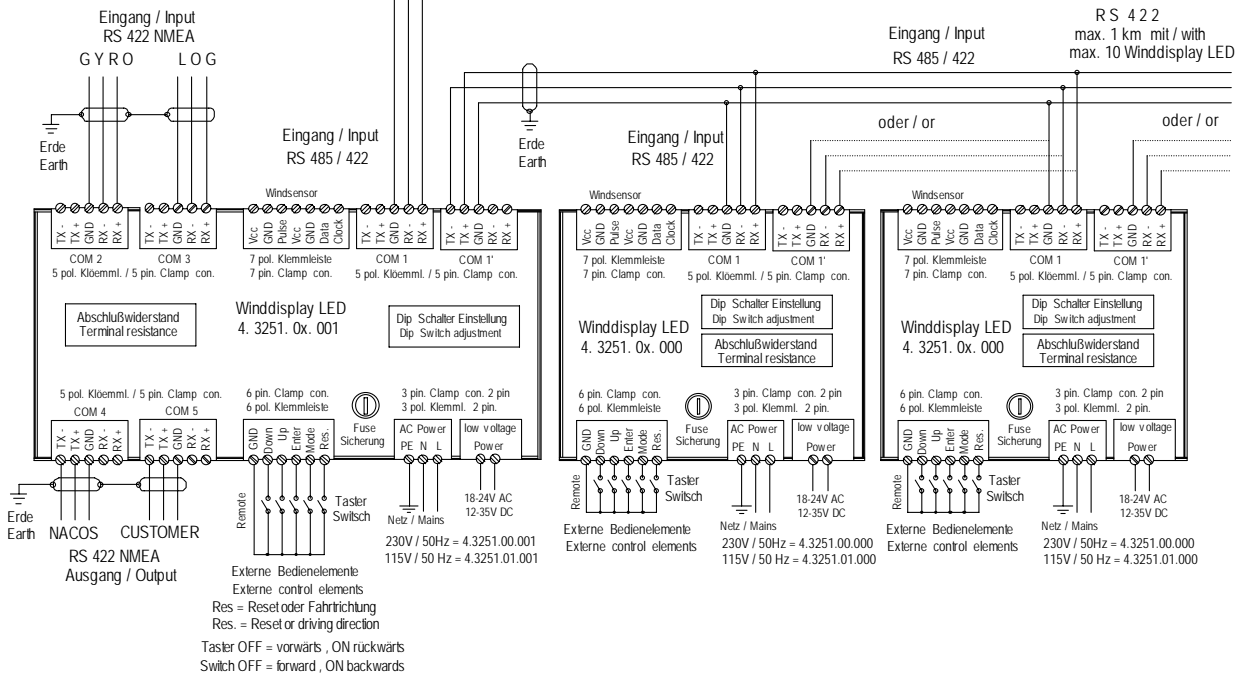
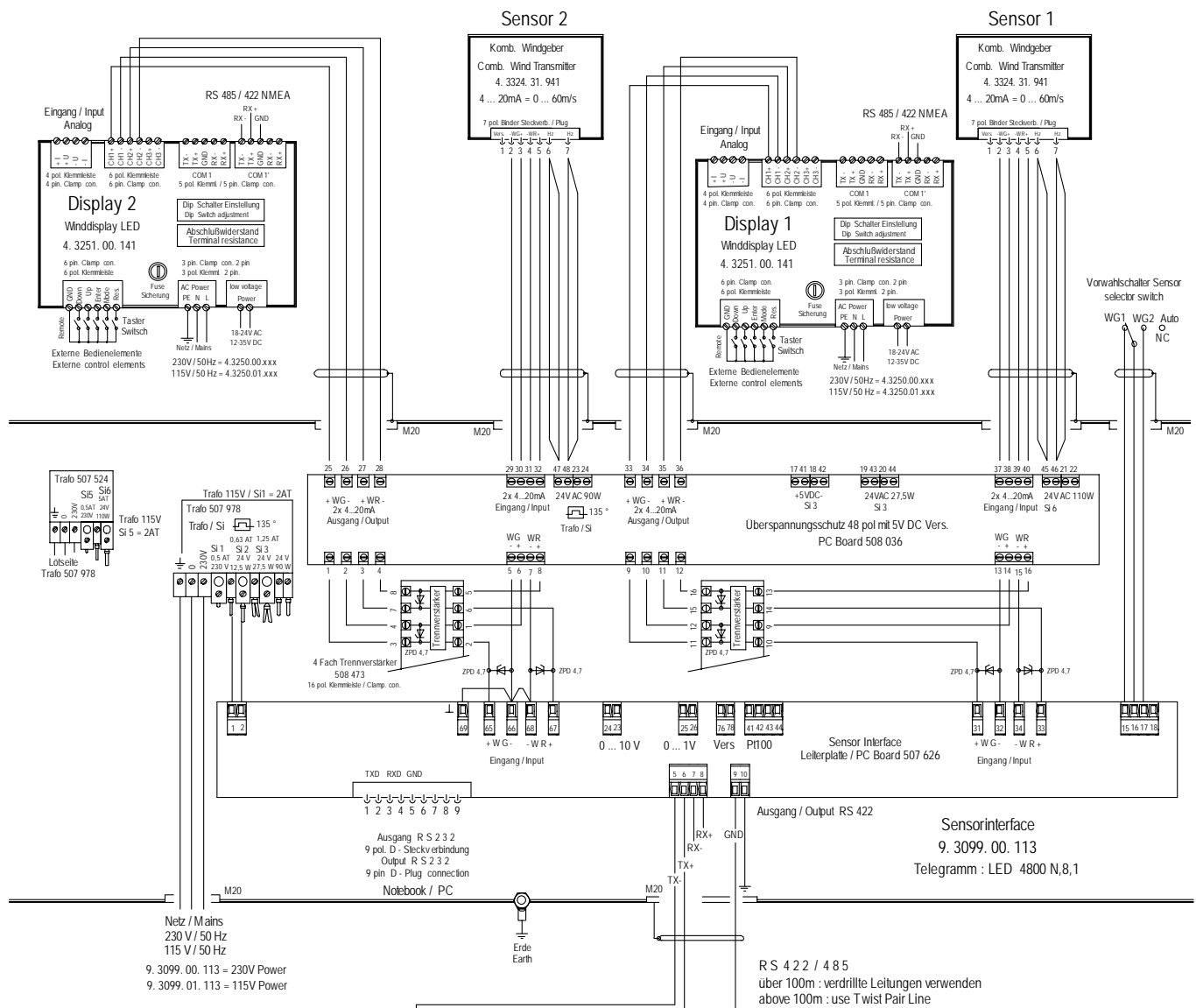

10 Technical Data

Sensor-Interface	
Connection box	
Supply voltage 9.3099.00.102 9.3099.01.102	Primary: 230 V AC 50 Hz Primary: 115 V AC 50 Hz
	Secondary: 1x 24 V AC 90 W 1 x 24 V AC 27,5 W 1 x 24 V AC 12,5 W 1 x 5 V DC 0,5W/100mA 1 x 24 V AC 110 W
Dimension	160 x 560 x 90 mm
Weight	5,5 kg
Protection	IP 65 acc. to DIN 40050
Wall mounting	Drilling template 110 x 540 mm
Housing	ALSi12 DIN 1725, varnished
Sensor interface pc-board	
Supply voltage	8...24V AC/DC
Power consumption	<20mA@12V DC (16mA typical)
Connections	Terminal strip pluggable
Operating temperature	-40°C to +85°C
Electromagnetic compatibility (EMC)	acc. to EN 61326 in conjunction with EN 61000-4-3
Telegram output rate	<3s (depending on number of connected measuring channels)
Analogue inputs unipolar	2 x 4...20mA
Accuracy	voltage-/power inputs +/- 0,1% FS
Serial Interfaces	1 x RS232 for operation, calibration, and telegram output baud rates: 1200,2400,4800,9600(default),19200,57600Bd 8N1 1 x RS422 for telegram output and sensor input Baud rates: 1200,2400,4800,9600(default),19200Bd 8N1
Lockable Sensors (Standard model)	2 x combined wind transmitters: 4.3324.31.941 (Type: CLASSIC) - velocity 4...20mA = 0...60m/s - direction 4...20mA = 0...360°

11 Dimensional Drawing

Outside dimensions: B x L x H 160 x 560 x 90mm

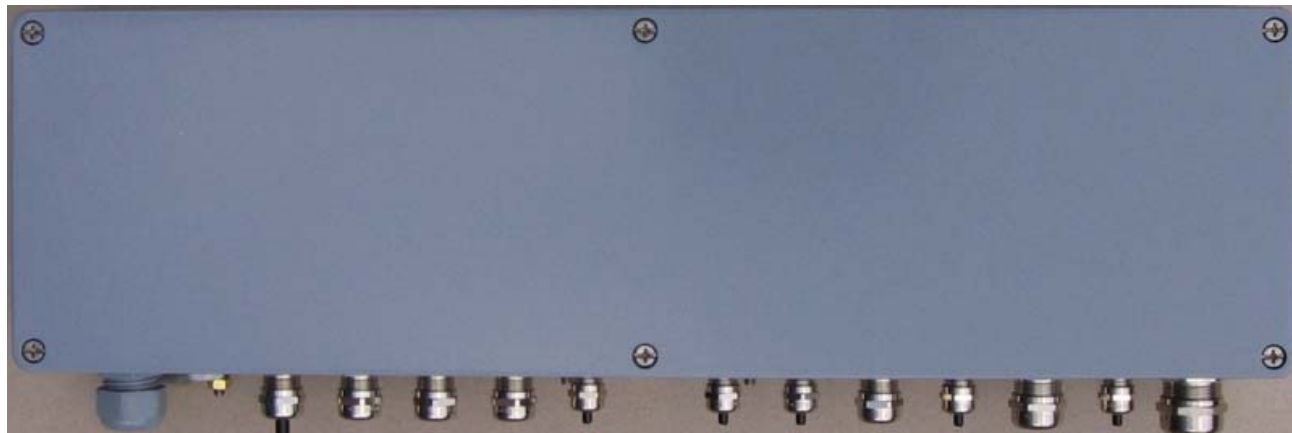

- Bore dimensions: please refer to backside of instrument

12 Accessories (optional)

<p>Installation kit compact serves for mounting the connection box (sensor interface) onto a mast. The installation kit consists of mounting holder and tensioning straps.</p>	<p>506 614</p>	<p>Techn. data: clamping range: Ø 48 ... 102 mm Material: stainless steel</p>
<p>Meteo- Online The software Meteo- Online is a WINDOWS program, functional under WINDOWS 98/2000/XP/2003. It serves for the visualization and filing of meteorological measuring values.</p>	<p>9.1700.98.000</p>	<p>Lockable data provider: for ex. sensor interface 9.3099.00.104</p>

13 EC-Declaration of Conformity

Document-No.: **000293**

Month: 01 Year: 09

Manufacturer: **ADOLF THIES GmbH & Co. KG**

Hauptstr. 76
D-37083 Göttingen
Tel.: (0551) 79001-0
Fax: (0551) 79001-65
email: Info@ThiesClima.com

Description of Product: **Sensor- Interface**

Article No.	9.3099.00.102	9.3099.01.102
	9.3099.00.113	9.3099.01.113
	9.3099.00.104	9.3099.01.104

specified technical data in the document: **021553/01/09; 021554/01/09; 021556/01/09**

The indicated products correspond to the essential requirement of the following European Directives and Regulations:

2004/108/EC	DIRECTIVE 2004/108/EC OF THE EUROPEAN PARLIAMENT AND OF THE COUNCIL of 15 December 2004 on the approximation of the laws of the Member States relating to electromagnetic compatibility and repealing Directive 89/336/EEC
2006/95/EC	DIRECTIVE 2006/95/EC OF THE EUROPEAN PARLIAMENT AND OF THE COUNCIL of 12 December 2006 on the harmonisation of the laws of Member States relating to electrical equipment designed for use within certain voltage limits
552/2004/EC	Regulation (EC) No 552/2004 of the European Parliament and the Council of 10 March 2004 on the interoperability of the European Air Traffic Management network (the interoperability Regulation)

The indicated products comply with the regulations of the directives. This is proved by the compliance with the following standards:

Reference number	Specification
IEC 61000-6-2: 2005	Electromagnetic compatibility Immunity for industrial environment
IEC 61000-6-3: 2006	Electromagnetic compatibility Emission standard for residential, commercial and light industrial environments
IEC 61010-1: 2001	Safety requirements for electrical equipment for measurement, control and laboratory use. Part 1: General requirements

Place: Göttingen

Date: 27.01.2009

Legally binding signature:

issuer:

.....
Wolfgang Behrens, General Manager

.....
Joachim Beinhorn, Development Manager

This declaration certifies the compliance with the mentioned directives, however does not include any warranty of characteristics. Please pay attention to the security advises of the provided instructions for use.



ADOLF THIES GmbH & Co. KG

Hauptstraße 76 37083 Göttingen Germany
P.O. Box 3536 + 3541 37025 Göttingen
Phone ++551 79001-0 Fax ++551 79001-65
www.thiesclima.com info@thiesclima.com



- Alterations reserved -