

---

## ***Precipitation Transmitter***

5.4032.35.007 / 008 / 009 / 010 / 011 / 107 / 108

5.4032.45.008 / 009



### **ADOLF THIES GmbH & Co. KG**

Hauptstraße 76  
Box 3536 + 3541  
Phone ++551 79001-0  
www.thiesclima.com

37083 Göttingen Germany  
37025 Göttingen  
Fax ++551 79001-65  
info@thiesclima.com

## **Contents**

1	Models .....	3
2	Application .....	3
3	Mode of Operation .....	3
4	Recommendation Site Selection / Standard Installation .....	4
5	Installation.....	4
5.1	Mechanical Mounting: .....	5
5.2	Electrical Mounting for Instruments with Plug: .....	6
5.3	Electrical Mounting for Instruments with Terminal strip:.....	6
6	Plug mounting.....	7
7	Maintenance .....	8
7.1	Cleansing Procedure.....	8
8	Check of the Tipping Bucket.....	9
9	Supply of Precipitation Transmitter to Output 1 .....	10
10	Connecting Diagram.....	11
11	Technical Data.....	13
12	Dimension diagram.....	14
13	Accessories .....	15
14	EC-Declaration of Conformity .....	16

## **Figure**

Figure 1: Instrument construction.....	5
Figure 2: plug mounting.....	7
Figure 3: Example - Connection to a Interface.....	10
Figure 4: Example - Connection to a SPS.....	10
Figure 5 : Dimensional drawing Precipitation Transmitter.....	14
Figure 6: Dim. drawing Precipitation transmitter with casing heating.....	14

# 1 Models

---

The precipitation transmitter can be delivered in the following versions:

Order- No.	Heating	Heating-Supply	Connection
5.4032.35.007	no	-----	Plug
5.4032.35.008	yes	24 V AC / DC; 48,5 W	Plug
5.4032.35.107	no	-----	Plug
5.4032.35.108	yes	24 V AC / DC; 48,5 W	Plug
5.4032.35.009	yes	42 V AC / DC; 48,5 W	terminal strip
5.4032.35.010	yes	24 V AC / DC; 48,5 W	terminal strip
5.4032.35.011	no	-----	terminal strip
5.4032.45.008	yes	24 V AC / DC; 113,5 W	Plug
5.4032.45.009	yes	42 V AC / DC; 118,5 W	terminal strip

Table1: Models

# 2 Application

---

The instrument is designed to measure the height, quantity and the intensity of the precipitation striking the surface of the earth. The measuring principle is basing on the description „Guide to Meteorological Instruments No 8“ of the WMO (World Meteorological Organization).

# 3 Mode of Operation

---

The rain, collected by the collecting surface of 200 cm<sup>2</sup>, is conducted through a inflow-sieve into a tipping-bucket. After having collected the rain amount of 2 cm<sup>3</sup> of precipitation the bucket tips over, and the other tipping-bucket halve is ready for collecting the rain.

This tipping procedure is detected by Hall-Sensors, and induces an output pulse in combination with connected electronics. The procedures recur with continuous precipitation.

---

$$2 \text{ cm}^2 \text{ tipping-bucket volume} = 1 \text{ tipping-bucket puls} = 0,1 \text{ mm precipitation}$$

---

Output 1: As the number of tipping procedures is not linear to the precipitation intensity, an intensity-dependent linearization is carried out in the connected electronics. The linearization procedure is basing on a intensity-dependent pulse-number-correction for the precipitation intensity range of approx. 0,5... 11 mm/min.

Each instrument is calibrated with a precipitation quantity of 200 cm<sup>3</sup> (=10 mm precipitation height).

Output 2: is available only as potential-free contact. This output is not linearized.

- Precipitation transmitters with optional integrated heating liquefy solid precipitation, such as snow, and are, therefore, suitable for winter operation
- Precipitation transmitters 5.4032.45.008 and 5.4032.45.009 have an additional casing heater, and so are particularly suited for the use in the mountains.
- All parts are corrosion-resistant. The cover is made of stainless steel (V2A).

---

**For information**

*A precipitation height of 1 mm corresponds to a water volume of 1 litre on 1 m<sup>2</sup> ground area.*

---

## 4 Recommendation Site Selection / Standard Installation

---

Depending on the wind velocity, a certain amount of the precipitation particles are blown away over the deposit area. Therefore, an installation in a completely open area as well as at the direct lee-side of an object is to be avoided. Gardens e.g., where hedgerows or similar objects offer protection against the wind, are more suitable.

The World Meteorological Organization recommends that precipitation gauges be installed at a distance which is at least four times as high as the next higher object. If this is not possible, it is to be observed that an elevation angle of  $\leq 45^\circ$  towards the surrounding plants, buildings etc. is adhered to.

The precipitation gauge is to be installed in such a way that the collection area is horizontal and is situated 1 m above ground. If snowfall is to be expected regularly within the area of the measuring instrument this distance should be increased respectively.

**Attention**

*Precipitation gauges are to be installed in a way that ensures a vibrationless operation.*

## 5 Installation

---

**Please Note:**

*The electrical connection is to be carried out by experts only.  
Please open the instrument only with dry ambient conditions.  
Do not damage the exposed electronics!*

## 5.1 Mechanical Mounting

Installation is carried out as follows:

(see also **Fig. 1: instrument construction**)

- Unpack the instrument.
- Remove the tipping bucket (9) from the collecting funnel of the casing (7) (in a separate small carton) and unpack it, as well.
- Put the precipitation transmitter onto an applicative stand and fix it by means of the screws (12).
- Unscrew 2 screws (1) at the casing (7) and remove the casing carefully.
- Check, if the level on the base plate (11) indicates vertical mounting, possibly correct it by means of the screws (12) in the stand.
- For inserting the tipping bucket (9) the collector (4) must be moved upwards by unscrewing the knurled screws.
- Then insert the tipping bucket carefully into the bearing seat.

**Important:** The magnet of the tipping-bucket must indicate towards the pc-board.

- Afterwards, check the tipping bucket if the tips go accurately.
- Then put the collector back into the lower position and fix it there.
- Replace carefully the case over the instrument from above and tighten the 2 housing screws.

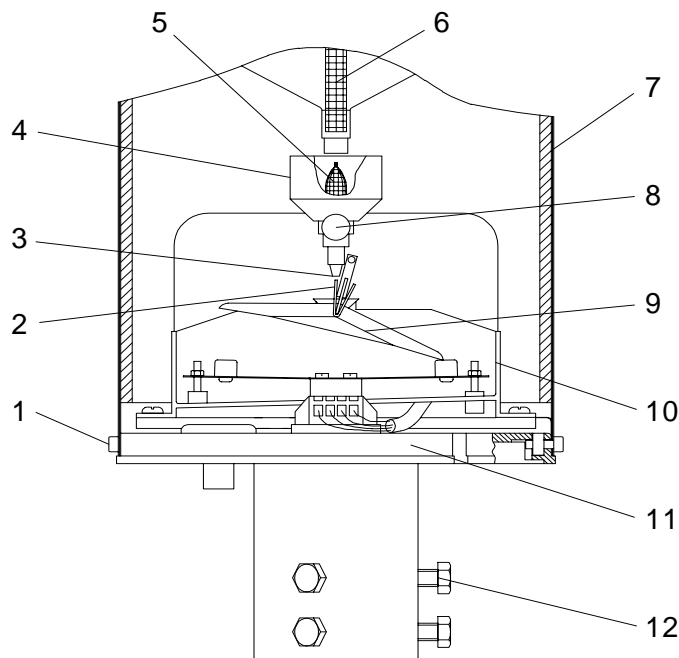

**Figure 1: Instrument construction**

**Attention**

*Do not touch the inner surfaces of the tipping bucket, and do not deform the draining pins (2).*

---

**Remark**

*Please remove the inflow sieve (6) in the collecting funnel during the winter period when it is snowing!*

---

## 5.2 Electrical Mounting for Instruments with Plug

- Please solder a cable (for ex.. LiYCY 0,5 mm<sup>2</sup> ) to the attached connecting plug acc. to the respective connecting diagram (see also chapter 10).
- Plug-mounting see chapter 6

---

**Remark**

*The connecting plug at the model without heating does not use connections 6 and 7.*

---

## 5.3 Electrical Mounting for Instruments with Terminal strip

- Please clamp a cable (for ex. LiYCY 0,5 mm<sup>2</sup> ) to the built-in terminal strip acc. to the respective connecting diagram (see also chapter 10).

---

**Remark**

*Connections 5 and 6 of the terminal strip are not used at the model without heating.*

---

## 6 Plug mounting

Applies only to instruments with connection „plug“.

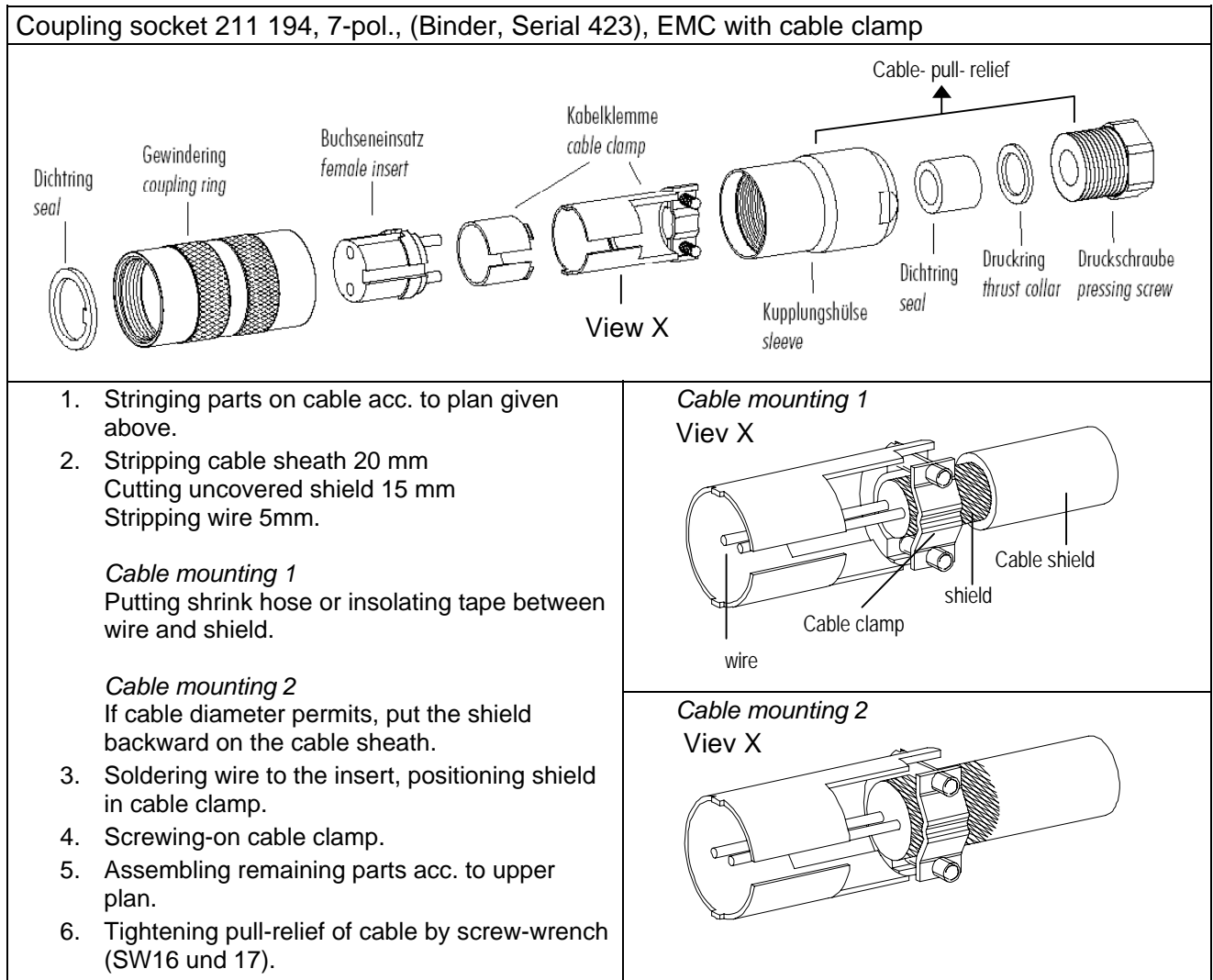

Figure 2: plug mounting

## 7 Maintenance

---



### **Please Note:**

***The electrical connection is to be carried out by experts only.  
Please open the instrument only with dry ambient conditions.  
Do not damage the exposed electronics!***

The instrument is designed in such a way that all of the parts requiring maintenance are easily accessible once the case has been removed.

The most important factors for precise measurements are a free and undisturbed inflow, and clean, grease-free inner surfaces of the tipping bucket.

The tipping bucket is made of zinc-plate, the surface of which is specifically oxidised, in order to achieve a hygrophile surface. It guarantees an accurate draining behaviour of the measuring liquid, and must not be removed mechanically.

The maintenance interval should depend on the degree of pollution of the instrument. It is advisable to make a visual inspection at short intervals as particles falling from above, such as foliage, bird dropping etc. can affect the measurement.

### 7.1 Cleansing Procedure

What you need for cleansing:

- ✓ a clean cloth
- ✓ a small bottle brush
- ✓ a soft brush
- ✓ possibly gentle soap

Cleansing is carried out as follows: (s.a. Fig. 1: Instrument construction):

- Switch off supply voltage of heating.
- Remove the **inflow sieve (6)** from the **case (7)** (collecting funnel) from above and clean it.
- Unscrew the **2 screws (1)** at the cover, remove and clean it.
- Remove **sieve (5)** from the **collector (4)** and clean it.
- The collector **(4)** with the **nozzle (3)** can be removed after unscrewing the knurled **screw (8)**. Clean the nozzle boring by means of small bottle brush.
- Remove the **tipping bucket (9)** carefully from the bearing seat.
- Clean the inner surfaces with clear water, if heavily soiled (grease) also with gentle soap water. For this, please use a soft brush.
- If indicated, clean also the **run-off pan (10)**.
- After cleansing, please re-insert the parts in reversed order.



**Attention**

- *Do not use any benzene, alcohol, or other cleansing agents.*
- *Never treat the inner surfaces of the tipping bucket with emery paper or something similar.*
- *Do not touch the inner surfaces with hands.*
- *Please take care that the draining pins are not deformed.*

## 8 Check of the Tipping Bucket

---

For checking the measuring instrument it is advisable to pour a certain amount of precipitation slowly and steadily into the collecting funnel. That means, that for example a quantity of 200 cm<sup>2</sup> induces a pulse number of 100.

The quantity of 200 cm<sup>2</sup> should be filled in constantly over a period of approx. 10 minutes.

---

**For Information**

*Approx. 98 % of the precipitation in Germany are falling with an intensity of 2 mm/min*

---

---

**Remark**

*Every precipitation transmitter is checked, adjusted and calibrated at the manufacturers. If, in the course of time, the adjustment of the tipping bucket has changed as a result of external influences, we suggest a check and calibration in our factory.*

---

## 9 Supply of Precipitation Transmitter to Output 1

---

The precipitation transmitter is supplied via the signal line (two-wire-circuit).

Example 1:

Therefore,  $R_a$  may be a maximum of  $10\text{k}\Omega$  in the interface at a voltage of  $V_{cc} = 5\text{V}$ .

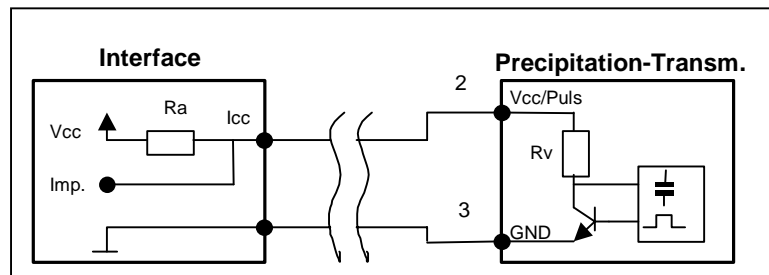

Figure 3: Example - Connection to a Interface

Example 2:

Connection to a SPS. The maximum pulse current (see Technical Data) must not be exceeded.

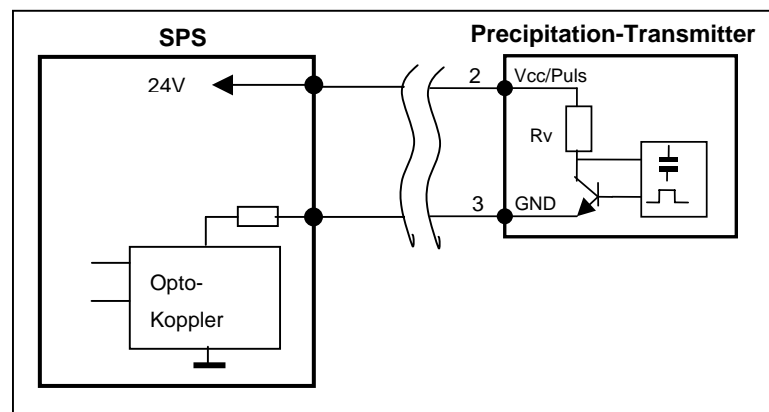

Figure 4: Example - Connection to a SPS

---

### Remark

*Output 2 is reserved just for acquisition systems, which can process only one Reed-contact. Output 2 is not linearized.*

---

# 10 Connecting Diagram

5.4032.35.007  
5.4032.35.008  
5.4032.45.008

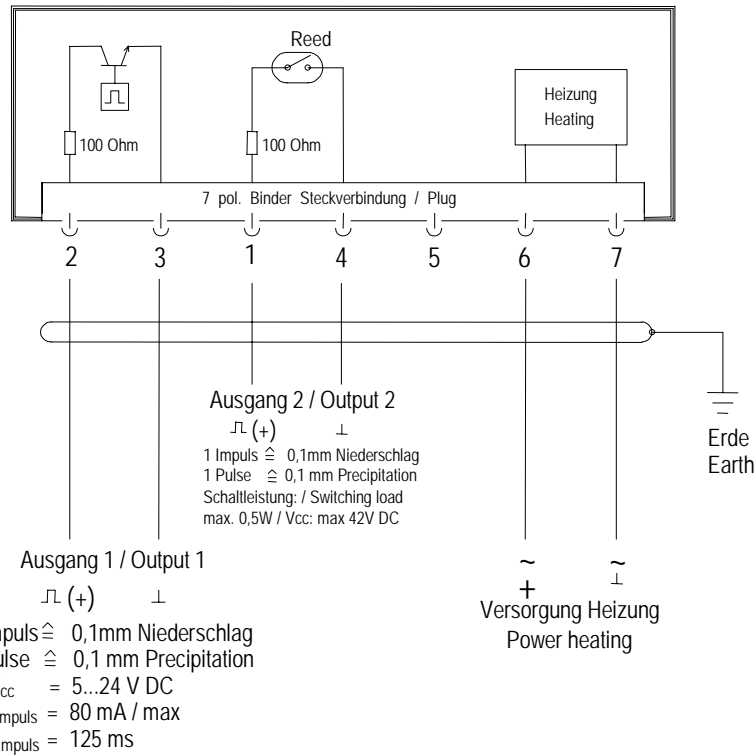

View on the soldered joint of the counter plug.

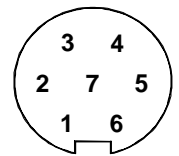

5.4032.35.107  
5.4032.35.108

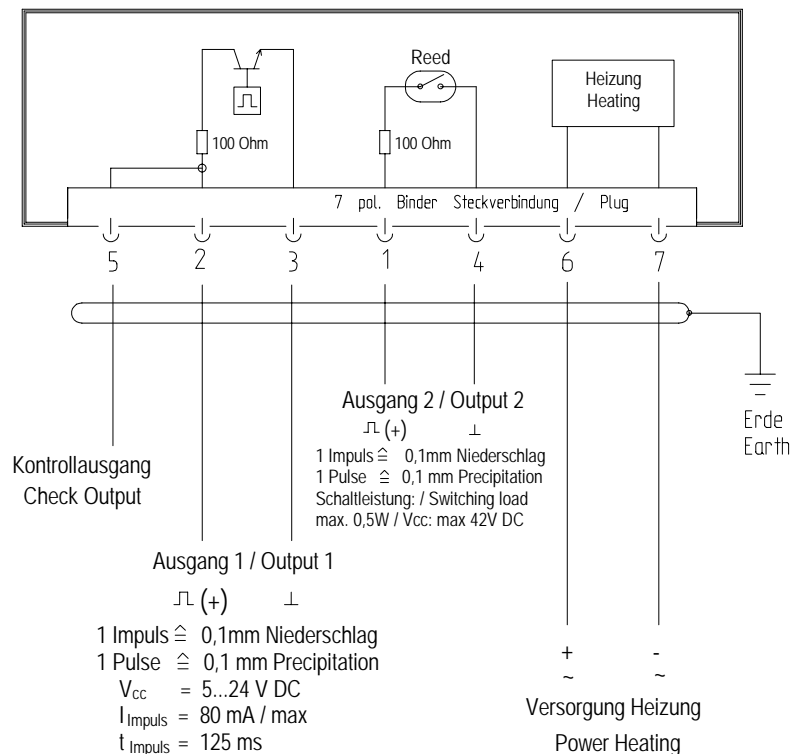

View on the soldered joint of the counter plug.

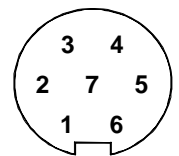

5.4032.35.009  
 5.4032.35.010  
 5.4032.35.011  
 5.4032.45.009

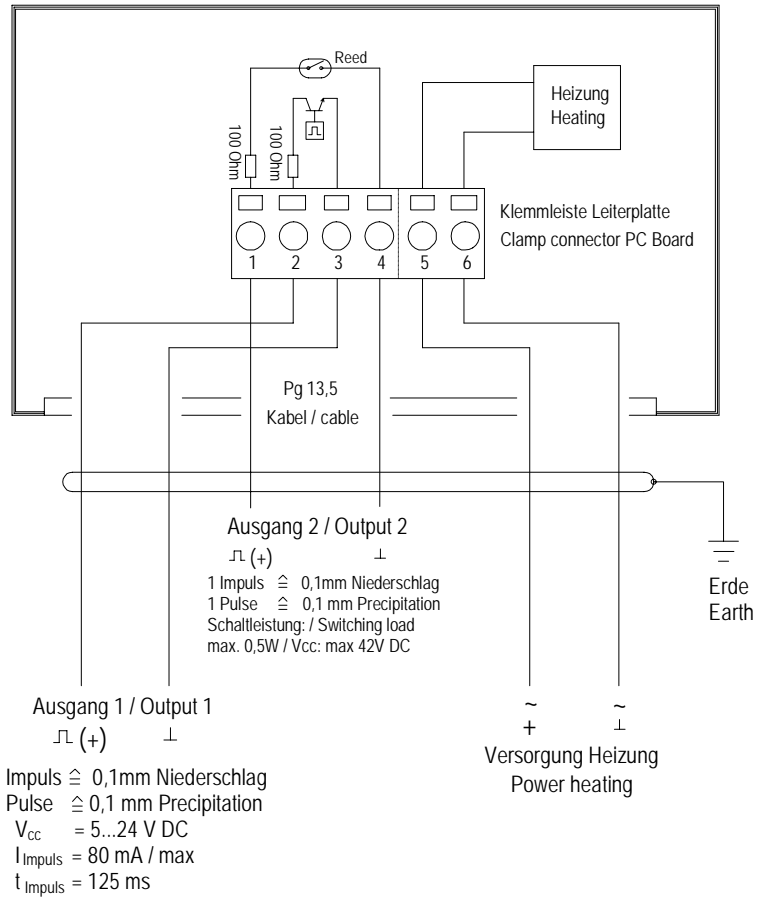

## 11 Technical Data

Description	MIN	TYP	Max	Units
<b>General</b>				
Collector surface		200		cm <sup>2</sup>
Volume of tipping bucket		2		cm <sup>3</sup>
Measuring range	0		11	mm/min
Measuring range		0,1		mm NS
Accuracy output 1 within the range of 0.. 11 mm/min			± 3 *	%
Ambient temperature ( without heating)	0		60	°C
Ambient temperature ( with heating)	- 25		60	°C
Mounting onto mast tube (1 ½")			50	Ømm
Weight			3.3	kg
<b>Output signal 1:</b>				
Pulse length		125		ms
Pulse pause		125		ms
Tipping bucket frequency	0		2	Hz
Operating voltage	5		24	V DC
Standing current (no precipitation)		50	56	µA
Pulse current			80	mA
Ra Max (Ra in the Interface (Vcc=5V) (fig.1)			10	kΩ
Rv (pre-resistance in the precip.transmitter) (fig.1)		100		Ω
<b>Output signal 2: Reed contact (without linearization)</b>				
Pulse length		50		ms
I Pulse frequency	0		2	Hz
Contact load			0.5	W
Contact voltage (Vcc)			42	V
<b>Heating:</b>				
Heating voltage (see model)		24 42		V (AC/DC)
Heating power (see model)		48.5 113.5 118.5		W
Heating – switch-on temperature		5		°C
Heating – hysteresis		2		°C

\* The accuracies were determined under laboratory conditions.  
 Test medium: distilled water.  
 Test volume: 200cm<sup>3</sup> = 10mm precipitation = 100 pulses of tipping bucket  
 10 mm of precipitation corresponds to a quantity of 600 l/h.

For information:  
 A precipitation height of 1 mm corresponds to a water volume of 1 litre on 1 m<sup>2</sup> ground area

## 12 Dimension diagram

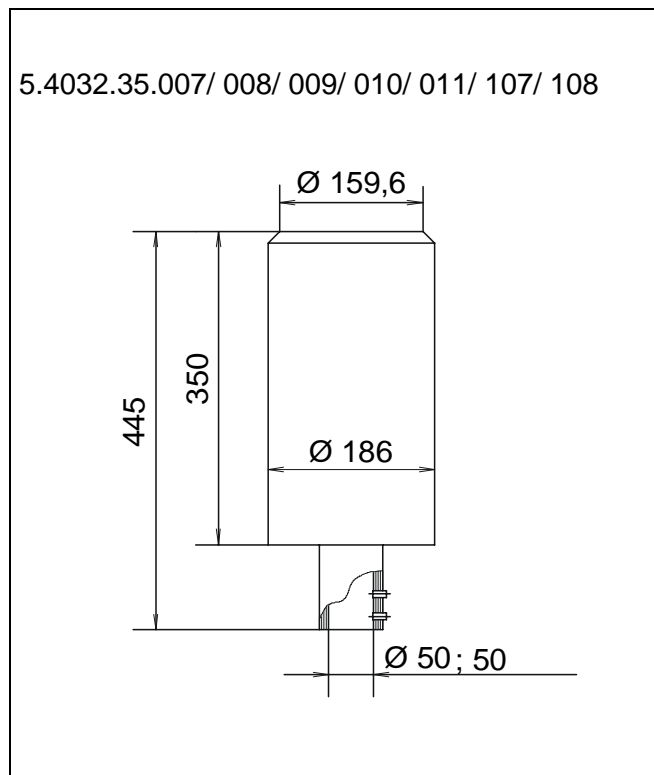

Figure 5 : Dimensional drawing Precipitation Transmitter

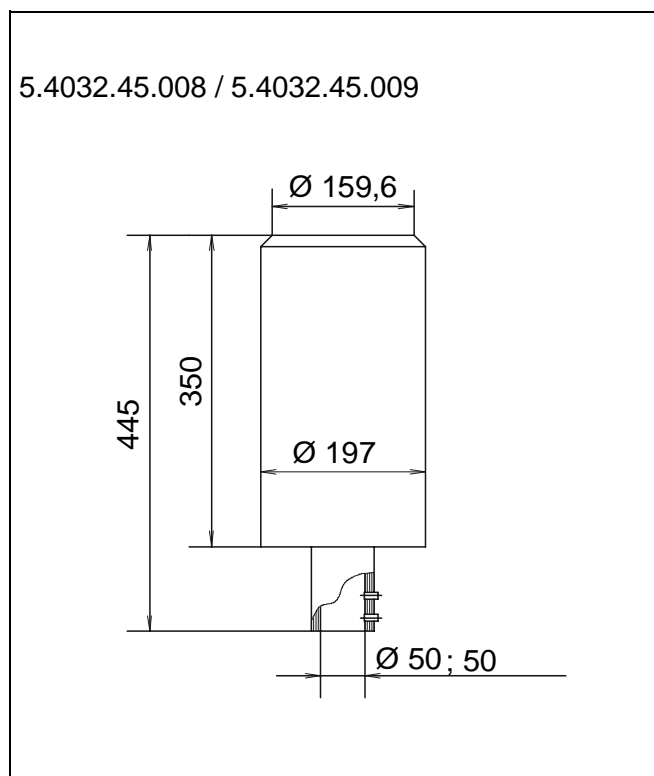

Figure 6: Dim. drawing Precipitation transmitter with casing heating

## 13 Accessories

*(deliverable as options)*

Stand 9.4031.35.065		Serves for mounting the precipitation transmitter. The distance from the ground to the collecting surface is about 1,0 meter. Stands are available also for other distances.
Bird protection device 5.4010.00.010	Suitable for 5.4032.35.007 / 008 / 009 / 010 5.4032.35.011 / 107 / 108	Avoids birds sitting on the precipitation transmitter.
Bird protection device 5.4010.00.011	Suitable for 5.4032.45.008 / 008	Avoids birds sitting on the precipitation transmitter.
Power Supply Unit 9.3388.00.000	Suitable for 5.4032.35.008 / 108 / 010	Serves for current supply of precipitation transmitter heating. Primary: 230 V / 50 Hz Secondary : 26V / 3,46 A
Power Supply Unit 9.3388.00.001	Suitable for 5.4032.45.008	Serves for current supply of precipitation transmitter heating. Primary: 230 V / 50 Hz Secondary : 24 V / 140 VA
Power Supply Unit 9.3388.00.001	Suitable for 5.4032.35.009 5.4032.45.009	Serves for current supply of precipitation transmitter heating. Primary: 230 V / 50 Hz Secondary : 42 V / 300 VA

Other accessories on request.

# 14 EC-Declaration of Conformity

Document-No.: 000901

Month: 02 Year: 09

Manufacturer: **ADOLF THIES GmbH & Co. KG**

Hauptstr. 76  
D-37083 Göttingen  
Tel.: (0551) 79001-0  
Fax: (0551) 79001-65  
email: Info@ThiesClima.com

Description of Product: **Precipitation Transmitter**

Article No.	<b>5.4032.35.007</b>	<b>5.4032.35.008</b>	<b>5.4032.35.009</b>	<b>5.4032.35.010</b>
	<b>5.4032.35.011</b>	<b>5.4032.35.018</b>	<b>5.4032.35.107</b>	<b>5.4032.35.108</b>
	<b>5.4032.35.228</b>	<b>5.4032.45.008</b>	<b>5.4032.45.009</b>	
	<b>5.4033.35.040</b>	<b>5.4033.35.041</b>	<b>5.4033.35.061</b>	<b>5.4033.35.073</b>
	<b>5.4033.36.040</b>	<b>5.4033.36.041</b>	<b>5.4033.36.061</b>	<b>5.4033.36.073</b>

specified technical data in the document: **021216/02/09; 021286/02/09; 021275/02/09; 021325/02/09**

The indicated products correspond to the essential requirement of the following European Directives and Regulations:

2004/108/EC	DIRECTIVE 2004/108/EC OF THE EUROPEAN PARLIAMENT AND OF THE COUNCIL of 15 December 2004 on the approximation of the laws of the Member States relating to electromagnetic compatibility and repealing Directive 89/336/EEC
2006/95/EC	DIRECTIVE 2006/95/EC OF THE EUROPEAN PARLIAMENT AND OF THE COUNCIL of 12 December 2006 on the harmonisation of the laws of Member States relating to electrical equipment designed for use within certain voltage limits
552/2004/EC	Regulation (EC) No 552/2004 of the European Parliament and the Council of 10 March 2004 on the interoperability of the European Air Traffic Management network (the interoperability Regulation)

The indicated products comply with the regulations of the directives. This is proved by the compliance with the following standards:

Reference number	Specification
IEC 61000-6-2: 2005	Electromagnetic compatibility Immunity for industrial environment
IEC 61000-6-3: 2006	Electromagnetic compatibility Emission standard for residential, commercial and light industrial environments
IEC 61010-1: 2001	Safety requirements for electrical equipment for measurement, control and laboratory use. Part 1: General requirements

Place: Göttingen

Date: 02.02.2009

Legally binding signature:

issuer:

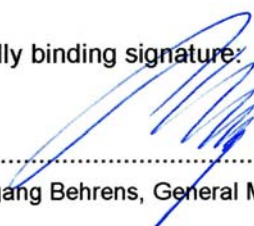
  
.....  
Wolfgang Behrens, General Manager

  
.....  
Joachim Beinhorn, Development Manager

This declaration certifies the compliance with the mentioned directives, however does not include any warranty of characteristics.  
Please pay attention to the security advises of the provided instructions for use.







## **ADOLF THIES GmbH & Co. KG**

Hauptstraße 76      37083 Göttingen Germany  
P.O. Box 3536 + 3541      37025 Göttingen  
Phone ++551 79001-0      Fax ++551 79001-65  
[www.thiesclima.com](http://www.thiesclima.com)      [info@thiesclima.com](mailto:info@thiesclima.com)



- Alterations reserved -