

# Ultrasonic Anemometer 2D

Operating Instructions 4.3800.20.xxx

(State:08/02)

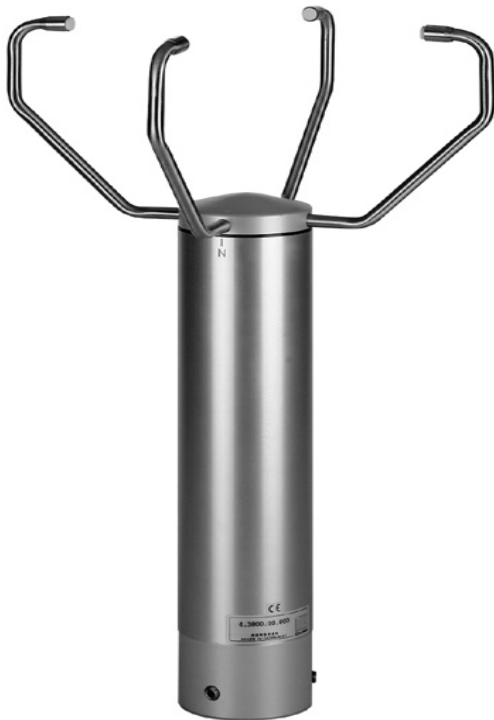

## 1. Range of Application

The **Ultrasonic Anemometer 2D** is designed to detect the horizontal components of wind speed and wind direction in two dimensions as well as the virtual temperature. Due to its very short measurement intervals, the instrument is ideal for the inertia-free measurement of gusts and peak values.

In certain weather situations the accuracy of the air temperature measurement (virtual-temperature) surpasses that one of the classic method where the temperature transmitter is used in a weather and thermal radiation shield.

The measured data are available as analogue signals and as a data telegram via a serial interface.

The ultrasonic transducers as well as its carrying arms are automatically heated so that the measuring results, in case of critical ambient temperatures, are not affected by icing rain or snow.

**Order no. with resp. model and factory setting see supplement sheet "Factory Setting"**

## 2. Mode of Operation

The **Ultrasonic Anemometer 2D** consists of 4 ultrasonic transducers, in pairs of 2 which are opposite each other at a distance of 200 mm.

The two measurement paths thus formed are vertical to each other.

The transformers act both as acoustic transmitters and acoustic receivers.

The respective measurement paths and their measurement direction are selected via the electronic control. When a measurement starts, a sequence of 4 individual measurements in all 4 directions of the measurement paths is carried out at maximum possible speed.

The measurement directions (acoustic propagation directions) rotate clockwise, first from south to north, then from west to east, from north to south and finally from east to west.

The mean values are formed from the 4 individual measurements of the path directions and used for further calculations.

A measurement sequence takes approx. 10 m/sec at +20°C.

### 3. Measurement Principle

#### 3.1 Wind speed and direction

The speed of propagation of the sound in calm air is superposed by the speed components of an air flow in wind direction.

A wind speed component in the direction of the propagation of the sound supports the speed of propagation, thus leading to an increase in the speed. A wind speed component opposite to the direction of propagation, on the contrary, leads to a reduction of the speed of propagation.

The speed of propagation resulting from the superposition leads to different propagation times of the sound at different wind velocities and directions over a fixed measurement path.

As the speed of sound is very dependent on the air temperature, the propagation time of the sound is measured on both of the measurement paths in both directions. In this way, the influence of the temperature-dependent speed of sound on the measurement result can be eliminated.

By combining the two measuring paths which are at right angles to each other, one obtains the measurement results of the sum and the angle of the wind speed vector in the form of rectangular components.

After the rectangular speed components have been measured, they are then transformed by the  $\mu$ -processor of the anemometer into polar co-ordinates and output as sum and angle of wind speed.

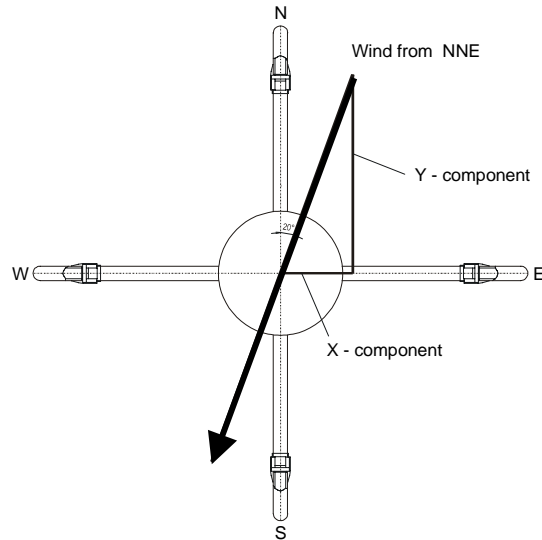

#### 3.2 Acoustic-Virtual Temperature

As previously mentioned, the speed of the propagation of sound is shows a radix dependency on the absolute air temperature, but is rather independent of air pressure, and only slightly dependent of humidity. Thus these physical properties of gases can be used to measure air temperature at constant and known chemical composition.

It is a measurement of gas temperature which is made without thermal coupling to a solid state sensor.

The advantages of this measured variable is, on the one hand, its inertia free reaction to the actual gas temperature, and, on the other hand, the avoidance of measurement errors such as those which occur when a solid state temperature sensor is heated up by radiation.

Due to the low dependency of the speed of propagation of the sound on the air humidity, the "Virtual Temperature" refers to dry air (0% humidity) under the same pressure conditions as that one actually measured.

The deviation of the measured "acoustic-virtual temperature", compared with the real air temperature, is linear-dependent from the absolute humidity content of the air.

The part of water vapour in the air increases proportionally the sonic speed, as H<sub>2</sub>O-molecules have approx. only half of the mass of the remaining air-molecules (O<sub>2</sub> and N<sub>2</sub>).

The rise of the sonic speed leads to an apparent (virtual) rising of the measured temperature in humid air compared with dry air of the same temperature.

The deviation of the measured virtual temperature in humid air, compared with real air temperature, can be corrected according to the following correlation, when the value of absolute humidity is given:

$$T_r = T_v - 0,135 \text{ K} \cdot \text{m}^3 / \text{g} \cdot a_{\text{abs}}$$

and  $T_r$  represents the real air temperature,  $T_v$  the measured acoustic-virtual temperature and  $a$  the absolute humidity in grams  $\text{H}_2\text{O}$  per  $\text{m}^3$  of air.

#### 4. Technical Data

<b>Wind Speed</b>	Meas. range	0...65 m/s The scaling of analogue outputs depends on the ordered instrument	
	Accuracy	$\pm 0.1$ m/s , at the range 0 ... 5 m/s resp. $\pm 2$ % rms from meas. value , at > 5 m/s	
	Resolution	0.1 m/s	
<b>Wind Direction</b>	Meas. range	0...360° 0...360° , 0...540° for analogue output, selectable	
	Accuracy	$\pm 1.0^\circ$	
	Resolution	1°	
<b>Virtual Temperature</b>	Meas. range	- 40 .... + 70 °C	
	Accuracy	$\pm 0.5$ K	
	Resolution	0.1 K	
<b>Data output</b>	<b>digital</b>	Interface	RS 485 / RS 422
		Baud rate	1200, 2400, 4800, 9600, 19200 selectable
		Output	Instantaneous values of speed, direction and Virtual .- temperature. Gliding mean values 1sec.; 10sec.; 1min.; 2min.; 10min.
		Output rate	1 per 100 m/sec up to 1 per 25.5 sec, selectable
		Status identification	Heater status, Path disturbance, temperature deviation path to path > 8 Kelvin
	<b>analogue</b>	Output	0 ... 20 mA / 0 ... 10 V or 4 ... 20 mA / 2 ... 10 V Only wind velocity and wind direction Load at current output max. 400 $\Omega$ Load at voltage output min. 4000 $\Omega$
		Output	Instantaneous values of wind speed and direction Gliding mean values 1sec.; 10sec.; 1min.; 2min.; 10min.
		Update rate	1 per 100 msec
		Resolution	12 bit
<b>General</b>	Internal meas. rate	400 measurements per second, at 25 °C	
	Temp. range	- 40 ... + 70 °C	
	Supply voltage	electronics, 12 ... 24 V AC/DC $\pm 10\%$ , max. 3 VA heater , 24 V AC/DC $\pm 10\%$ , max. 77 VA (typ. 70 VA)	
	Protection	IP 65 (only valid in accordance with mounting instruction, see also Item 11.2 u. 12)	
	Icing	acc. to THIES STD 012002	
	Corrosion	No corrosion after 3 month of salt fog and condensation	
	EMV	EN 55022 5/95 class B; EN50082-2 2/96	
	Model	V4A Stainless steel for housing and sensor arms	
	Mounting	to a mast tube 1 ½ ", for ex. DIN 2441	
	Type of connection	16 pole plug connection in the shaft	
Weight	approx. 2.5 kg		

## 5. Plug Connection Assignment

Pin-No.	Function	Remark
1 (A)	Analogue output current WV	0 / 4 – 20 mA
2 (B)	Analogue output current WD	0 / 4 – 20 mA
3 (C)	Analogue Ground	AGND
4 (D)	Analogue output voltage WV	0 / 2 – 10 V
5 (E)	Analogue output voltage WD	0 / 2 – 10 V
6 (F)	TX+	serial interface
7 (G)	RX+	serial interface
8 (H)	GND	serial interface
9 (I)	RX-	serial interface
10 (K)	TX-	serial interface
11 (L)	Power electronics 12 ... 24V AC/DC	
12 (M)	Power electronics 12 ... 24V AC/DC	
13 (N)	Power heater 24 V AC/DC	bridged with PIN 14
14 (O)	Power heater 24 V AC/DC	bridged with PIN 13
15 (P)	Power heater 24 V AC/DC	bridged with PIN 16
16 (R)	Power heater 24 V AC/DC	bridged with PIN 15

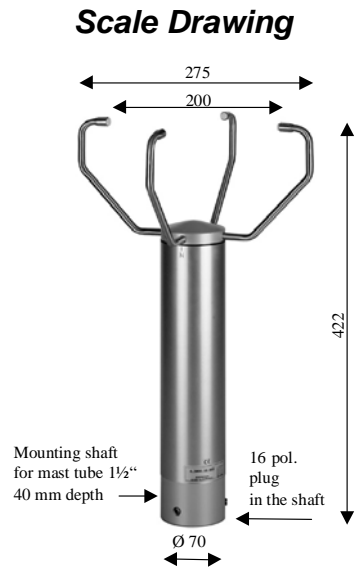

### 5.1 Remarks concerning Power Supply of Instrument:

The connecting cables for the heating (13 u. 14; 15 u. 16) must be bridged on the supply side in order to guarantee the complete heating power!

The electronics is additionally supplied uncoupled via diodes through the heating connections 13,14, and 15, 16.

If the heating voltage exceeds the supply voltage the heating voltage takes on the supply of the electronics That means, in case of heating supply (PIN 13,14,15 and 16) with 24 V the supply of the electronics is inapplicable.

## 6. Interface Description

### 6.1 Telegram forms

#### 6.1.1 Telegram VD

(STX)xx.x xxx\*xx(CR)(ETX)

Z. NR.	FUNCTION
1	STX (HEX 02)
2	10 <sup>1</sup> Wind speed
3	10 <sup>0</sup> Wind speed
4	“.” Decimal point
5	10 <sup>-1</sup> Wind speed
6	space (HEX 20)
7	10 <sup>2</sup> Wind direction
8	10 <sup>1</sup> Wind direction
9	10 <sup>0</sup> Wind direction
10	* (HEX 2A) Check sum identifier
11	High Byte check sum in HEX
12	Low Byte check sum in HEX
13	CR (HEX 0D) Carriage return
14	ETX (HEX 03)

#### 6.1.2 Telegram VDT

(STX)xx.x xxx xxx.x x\*xx(CR)(ETX)

Z. NR.	FUNCTION
1	STX (HEX 02)
2	10 <sup>1</sup> Wind speed
3	10 <sup>0</sup> Wind speed
4	“.” (HEX 2E) Decimal point
5	10 <sup>-1</sup> Wind speed
6	Space (HEX 20)
7	10 <sup>2</sup> Wind direction
8	10 <sup>1</sup> Wind direction
9	10 <sup>0</sup> Wind direction
10	Space (HEX 20)
11	+ or - sign
12	10 <sup>1</sup> Temperature
13	10 <sup>0</sup> Temperature
14	“.” (HEX 2E) Decimal point
15	10 <sup>-1</sup> Temperature
16	Space (HEX 20)
17	High Byte status byte
18	Low Byte status byte
19	* (HEX 2A) Check sum identifier
20	High Byte Check sum in HEX
21	Low Byte Check sum in HEX
22	CR (HEX 0D) Carriage return
23	ETX (HEX 03)

### 6.1.2.1 Telegram VDT

### (STX)xx.x xxx xxx.x xx\*xx xx.x xxx(CR)(ETX)

When using the standard deviation the VDT-telegram is extended by the standard deviations of wind speed and wind direction.

Z. NR.	FUNCTION
1	STX (HEX 02)
2	10 <sup>1</sup> Wind speed
3	10 <sup>0</sup> Wind speed
4	. (HEX 2E) Decimal point
5	10 <sup>-1</sup> Wind speed
6	Space (HEX 20)
7	10 <sup>2</sup> Wind direction
8	10 <sup>1</sup> Wind direction
9	10 <sup>0</sup> Wind direction
10	Space (HEX 20)
11	+ or - sign
12	10 <sup>1</sup> Temperature
13	10 <sup>0</sup> Temperature
14	. (HEX 2E) Decimal point
15	10 <sup>-1</sup> Temperature
16	Space (HEX 20)
17	10 <sup>1</sup> Wind speed (Standard deviation)
18	10 <sup>0</sup> Wind speed (Standard deviation)
19	. (HEX 2E) Decimal point
20	10 <sup>-1</sup> Wind speed (Standard deviation)
21	Space (HEX 20)
22	10 <sup>2</sup> Wind direction (Standard deviation)
23	10 <sup>1</sup> Wind direction (Standard deviation)
24	10 <sup>0</sup> Wind direction (Standard deviation)
25	Space (HEX 20)
26	High Byte statusbyte
27	Low Byte statusbyte
28	* (HEX 2A) Check sum identifier
29	High Byte Check sum in HEX
30	Low Byte Check sum in HEX
31	CR (HEX 0D) Carriage Return
32	ETX (HEX 03)

**6.1.3 Telegram V4DT (STX)xxx.x xxx xxx.x x xx\*xx(CR)(ETX)**

Z. NR.	FUNCTION
1	STX (HEX 02)
2	10 <sup>2</sup> Wind speed
3	10 <sup>1</sup> Wind speed
4	10 <sup>0</sup> Wind speed
5	. (HEX 2E) Decimal point
6	10 <sup>-1</sup> Wind speed
7	Spare (HEX 20)
8	10 <sup>2</sup> Wind direction
9	10 <sup>1</sup> Wind direction
10	10 <sup>0</sup> Wind direction
11	Space (HEX 20)
12	+ or - Sign
13	10 <sup>1</sup> Temperature
14	10 <sup>0</sup> Temperature
15	. (HEX 2E) Decimal point
16	10 <sup>-1</sup> Temperature
17	Space (HEX 20)
18	K, N, M, S = km/h, Knots, m/s, mph
19	Space (HEX 20)
20	High Byte Status byte
21	Low Byte Status byte
22	* (HEX 2A) Check sum identifier
23	High Byte Check sum in HEX
24	Low Byte Check sum in HEX
25	CR (HEX 0D) Carriage return
26	ETX (HEX 03)

6.1.4 Telegram NMEA V 2.0

\$WIMWV,xxx.x,R,xxx.x,N,A\*xx(CR)(LF)

Z. NR.	FUNCTION
1	\$ (HEX 24) Dollar
2	W (HEX 57)
3	I (HEX 49)
4	M (HEX 4D)
5	W (HEX 57)
6	V (HEX 56)
7	, (HEX 2C) Comma
8	10 <sup>2</sup> Wind direction
9	10 <sup>1</sup> Wind direction
10	10 <sup>0</sup> Wind direction
11	. (HEX 2E) decimal point
12	10 <sup>-1</sup> Wind direction
13	, (HEX 2C) Comma
14	R (HEX 52)
15	, (HEX 2C) Comma
16	10 <sup>2</sup> Wind speed
17	10 <sup>1</sup> Wind speed
18	10 <sup>0</sup> Wind speed
19	. (HEX 2E) Decimal point
20	10 <sup>-1</sup> Wind speed
21	, (HEX 2C) Comma
22	K, N, M, S = km/h, Knots, m/s, mph
23	, (HEX 2C) Comma
24	A, V A = valid, V = non valid
25	* (HEX 2A) Check sum identifier
26	High Byte Check sum in HEX
27	Low Byte Check sum in HEX
28	CR (HEX 0D) Carriage Return
29	LF (HEX 0A) Line Feed



## 6.2 Definition of Checksum and Status byte

### 6.2.1 Forming of Checksum

The checksum is the result of the byte-wise EXOR-combination of the bytes output in the telegram. The EXOR-combination comprises all bytes between the telegram start sign „STX“, or “\$” within the NMEA-telegram, and the byte “\*” as identifier for starting the checksum. Thus, the bytes „STX“ or. „\$“ and „\*“ will not be taken into consideration with the checksum calculation!

### 6.2.2 Definition of Status Byte

The status byte contains information about the current state of the system. The information comprises:

- error events with the measurement value acquisition
- a possible de-calibration caused, e.g., by a change in the measurement path length (due to mechanical deformation of the transducer carrying arms)
- the operation state of the instrument heating.

<b>Bit 0</b>	<b>0 = no error</b>	<b>1 = general error event, measurement value probably correct, measurement value acquisition disturbed</b>
<b>Bit 1</b>	<b>0 = no error</b>	<b>1 = error event, deviation of the virtual temperature between both measurement paths is &gt; 8 K.</b>
<b>Bit 2</b>	<b>reserved</b>	
<b>Bit 3</b>	<b>0 = heating switched off</b>	<b>1 = Heating switched on</b>
<b>Bit 4 to 7</b>	<b>reserved</b>	

The error event reported by Bit 0 does not necessarily cause the output of an erroneous measurement value. Certain weather conditions like extreme precipitation and snowfall may disturb the measurement acquisition for a short time, caused by sonic burst-echoes at the precipitation particles. Such an event, however, is realized by a plausibility-algorithm, which leads to an immediate re-measurement of the instrument – until a correct value is available. The output measurement value is generally correct, in spite of the reported error, and does not contain the erroneous data.

If Bit 1 is continuously set during the operation, you should reckon on a de-calibration of the instrument due to mechanical deformation of the measurement arms.

## 6.3 Analogue Value Output

The analogue output is available only for wind speed, and wind direction.

The output signal of the wind speed corresponds to the measuring range of the wind speed. The measuring range of the wind direction 0...360 ° or 0...540 ° is selectable, and corresponds to the output signal, for example 0...20 mA = 0...360 °.

The measuring range of the wind direction 0...360 ° or 0...540° is selectable, and corresponds to the output signal e.g. 0...20 mA = 0...360°

WR – relation at 0..360° :

0° / 360° = north; 90° = east; 180° = south; 270° = west

WR – relation at 0..540° (acc. to VDI 3786 sheet 2):

0° = west; 90° = north; 180° = east; 270° = south; 360° = west; 450° = north; 540° = east

Remark: In case of calm the output signal is always “North”.

## 6.4 Telegram Output and Analogue Value Output in Case of Error Events

In the following cases the digital telegram outputs „F“ as measurement value figure instead of numbers:

- If the measurement acquisition is constantly disturbed for more than 10 seconds in spite of multiple measurements
- If the deviation of the virtual temperature between both measurement paths is > 8 K.

The following options are available as analogue output:

1. for the wind speed **and** wind direction with the minimum value for voltage/ current (0 V, 0 mA) (for EI 00001)
2. for the wind speed with the minimum value for voltage/current (0 V, 0 mA) **and** for the wind speed with the maximum value for voltage/current (10 V; 20 mA) (ref. factory adjustment) (for EI 00000)

## **7. Averaging Procedure:**

The Ultrasonic 2D forms the gliding mean value through a FIFO-memory the capacity of which comprises up to 600 values.

In the free running measurement mode the measurement data rate is exactly 10 Hz or 100msec, and forms, at the same time, the updating rate for the averaging memory (FIFO-memory).

If averaging is requested the measured data are recorded in the FIFO-memory stated above, the capacity of which is built-up depending on the selected averaging period.

If the averaging period is, for example, 10 seconds, 100 memory cells are used, and in case of an averaging period of 1 minute 600 cells.

From a selected averaging period > 1 minute up the data flow will be pre-averaged; because the memory capacity of 600 values cannot be exceeded.

The Ultrasonic 2 D combines two different and useful procedures of mean value forming:

- The forming of vectorial mean values
- The forming of scalar mean values

These different procedures can be selected for the averaging of both the wind speed and wind direction, depending on the application.

The procedure of forming the vectorial mean value takes the wind direction into account when averaging the wind speed and vice versa.

Thus, the averaged dimensions of wind speed and wind direction are valued each one with the other.

This procedure of forming the mean value is well suited, for example, for measurements and analysis of pollutant-propagation.

The procedure of forming the scalar mean value averages both dimensions of wind speed and wind direction independently from each other.

These averaging procedures lead to results comparable with mechanical wind speed- and wind direction transmitters.

The scalar averaging procedure is suited, for example, for location-analysis for wind power plants, where only the dimension of the wind vector – important for power generation – is interesting but not its direction.

The vectorial and scalar procedure can be used independently with wind speed and wind direction within an output telegram.

For this, you have to select one of the four possible combinations through the command **AM (Average Method)**.

**Command for selecting the averaging procedure:**

**AM00000 (Average Method) vectorial averaging of speed and direction**

**AM00001 scalar averaging of speed and direction**

**AM00002 scalar averaging of speed and vectorial averaging of direction**

**AM00003 vectorial averaging of speed and scalar averaging of direction**

## 8. Standard Deviation

Starting with the firmware version V 1.8 the ULTRASONIC is capable to calculate the standard deviation. The standard deviation for wind speed and wind direction is determined at an averaging period of > 1 sec. The calculation is carried out in accordance with the following formula:

$$Y = \sqrt{\frac{1}{n} \sum_{i=0}^{i<n} (\bar{M} - X_i)^2} \quad \text{with} \quad \bar{M} = \frac{1}{n} \sum_{i=0}^{i<n} X_i$$

The standard deviation is activated through the command "DE00001". It is important that the ULTRASONIC reduces the measuring interval to 50 hz when calculating the standard deviation. This is necessary for the instrument to finish the calculations of the standard deviations between two measuring cycles. The calculation of the standard deviation is activated when the selected averaging period is > 1sec.

## 9. Bus-Ability, Synchronisation of the Measurement on the Query Telegram:

### 9.1 Duplex-Mode

The Ultrasonic supports absolutely any operation at an RS485/RS422 data bus in co-operation with further instruments (bus operation).

Supported are both semi-duplex bus-topologies and full duplex bus-systems.

In the semi- and full duplex operation the line drivers of the Ultrasonic are active only for the time of data transmission.

The remaining time the line drivers are off-line ("three-state-mode").

The direct connection to a PC with RS232 interface makes an interface-converter RS 485 / RS 232 necessary, e.g. our accessories order-no. 9.1702.20.000

#### Command for Selecting the duplex-mode (DM for duplex mode):

**DM00000** for semi-duplex (2-wire operation)

**DM00001** for full duplex (4-wire operation) (state of delivery).

In case of bus operation a spontaneous output of the Ultrasonic is suppressed – the instruments respond only on request of the bus master.

When semi-duplex operation is set, a spontaneous telegram output is not selectable.

In case the spontaneous telegram output has been selected erroneously this could lead to a blocking of the receivers at slow baud rates.

### 9.2 Synchronisation on Data Query

Certain application make it necessary to interrogate cyclically a collective of instruments within a short time (e.g. 5 instruments within 100 ms).

There might be the following problem: the Ultrasonic can be contacted during a measurement by the asynchronous query and is then not ready for transmission.

In order to guarantee an immediate instrument response without delay, the possibility of temporal measurement synchronisation on the query is used.

#### Command for activating the ability for measurement-synchronisation on the query:

**MT00001** (Measurement Trigger) Synchronisation Ability on.

**MT00000** Synchronisation Ability off.

In case the instrument receives, with active synchronisation, a telegram inquiry through the command TR0000x, and further inquiry follow with intervals of less than 2,5 seconds, the instrument runs synchronously to the inquiries and responds with smallest possible delay.

If there are no queries for more than 2,5 seconds, the instrument leaves the synchronous mode and changes into a spontaneous measurement value acquisition.

This return to the spontaneous mode of measurement guarantees that all control functions derived from the measurement data (e.g. switch-on heating etc.) will be able to operate also in case of a failure of query telegram.

As soon as a new query occurs in the spontaneous mode the instrument synchronises immediately on the query telegram.

### **9.3 Averaging with Active Synchronisation**

In case the measurement values should be averaged please take care that – with active synchronisation – the exact, internal time basis of 100 ms for forming the measurement values is not used. In this case, the time is determined by the query-repetition-rate.

**It is advisable to switch-off the synchronisation ability if it is not absolutely necessary.**

## **10. List of control commands**

The Anemometer 2D can be controlled via its serial data interface using the commands in the following list. Any standard terminal program such as "procomm" , "telix" or a *Windows* terminal program (e.g. "*Hyper Terminal*") can be used.

**All adjustments are stored in a E<sup>2</sup>ROM so that the adjusted parameters cannot get lost after switching off or failure of power supply.**

## 10.1 List of commands

Command	Function	Remark
<ID> AM 00000	Vectorial averaging	<b>Vectorial averaging of wind speed and direction</b>
<ID> AM 00001	Scalar averaging	Scalar averaging of wind speed and direction
<ID> AM 00002	Scalar / vectorial averaging	Scalar averaging of speed / vectorial averaging of direction
<ID> AM 00003	Vectorial / Scalar averaging	Vectorial averaging of speed / scalar averaging of direction
<ID> AO 00000	Wind direction output 0-360°	Scaling of the analogue output
<ID> AO 00001	Wind direction output 0-540°	Scaling of the analogue output
<ID> AV 00000	Instantaneous value	<b>Output of the instantaneous values</b>
<ID> AV 00001	Mean value over 1 second	Output of the gliding mean value over 1 second
<ID> AV 00002	Mean value over 10 seconds	Output of the gliding mean value over 10 seconds
<ID> AV 00003	Mean value over 1 minute	Output of the gliding mean value over 1 minute
<ID> AV 00004	Mean value over 2 minutes	Output of the gliding mean value over 2 minutes
<ID> AV 00005	Mean value over 10 minutes	Output of the gliding mean value over 10 minutes
<ID> BR 00002	1200 Baud N 8 1	Data rate 1200 Baud, 8 Data bits, No Parity, 1 Stop bit
<ID> BR 00010	1200 Baud E 7 1	Data rate 1200 Baud, 7 Data bits, Parity Equal, 1 Stop bit
<ID> BR 00003	2400 Baud N 8 1	Data rate 2400 Baud, 8 Data bits, No Parity, 1 Stop bit
<ID> BR 00011	2400 Baud E 7 1	Data rate 2400 Baud, 7 Data bits, Parity Equal, 1 Stop bit
<ID> BR 00004	4800 Baud N 8 1	Data rate 4800 Baud, 8 Data bits, No Parity, 1 Stop bit
<ID> BR 00012	4800 Baud E 7 1	Data rate 4800 Baud, 7 Data bits, Parity Equal, 1 Stop bit
<ID> BR 00005	9600 Baud N 8 1	Data rate 9600 Baud, 8 Data bits, No Parity, 1 Stop bit
<ID> BR 00013	9600 Baud E 7 1	Data rate 9600 Baud, 7 Data bits, Parity Equal, 1 Stop bit
<ID> BR 00006	19200 Baud N 8 1	Data rate 19200 Baud, 8 Data bits, No Parity, 1 Stop bit
<ID> BR 00014	19200 Baud E 7 1	Data rate 19200 Baud, 7 Data bits, Parity Equal, 1 Stop bit
<ID> DE 00000	Standard deviation of	<b>De-activate calculation of the standard deviation</b>
<ID> DE 00001	Standard deviation on	Activate calculation of the standard deviation
<ID> DM 00000	Duplex mode half duplex (HD)	Half duplex, 2-wire operation
<ID> DM 00001	Duplex mode full duplex (FD)	<b>Full duplex, 4-wire operation</b>
<ID> DV	Firmwareversion	Release of firmware version
<ID> EI 00000	Error with analogue output	Voltage-/ current value: WS = 0 ; WD = max
<ID> EI 00001	Error with analogue output	Voltage-/ current value: WS = 0 ; WD = 0
<ID> ES 00000	Sign-echo switched off	Echo operation of transmitted characters switched off
<ID> ES 00001	Sign-echo switched on	Echo operation of transmitted characters switched on
<ID> KY 00000	Key, no access	Software-key, access to EEPROM closed
<ID> KY 00001	Key, open access	Software- key, access to EEPROM open
<ID> MT 00000	Measurement trigger off	<b>No synchronization of measurement onto request poss.</b>
<ID> MT 00001	Measurement trigger on	<b>Synchronization of measurement onto request possible</b>
<ID> NC 00xxx	North correction in 1°	Input of north correction, value range 00000 up to 00360
<ID> OR 00xxx	Output rate online (spontaneous)	Output rate xxx times 100ms, value range 00001 up to 00255
<ID> OS 00000	Wind speed in m/s	Scale of Wind speed in meter per second
<ID> OS 00001	Wind speed in Km/h	Scaling of Wind speed in kilo meter per hour
<ID> OS 00002	Wind speed in mph	Scaling of Wind speed in miles per hour
<ID> OS 00003	Wind speed in Knots	Scaling of Wind speed in knots (nautically)
<ID> SC 00000	Start value of current 0mA	Analogue output current 0 - 20mA / 0 – 10 V
<ID> SC 00001	Start value of current 4mA	Analogue output current 4 - 20mA / 2 – 10 V
<ID> TR 00000	no Telegram on request	
<ID> TR 00001	Telegram VD on request	single output of the telegram form, see 6.1.1
<ID> TR 00002	Telegram VDT on request	single output of the telegram form, see 6.1.2
<ID> TR 00003	Telegram V4DT on request	single output of the telegram form, see 6.1.3
<ID> TR 00004	Telegram NMEA on request	single output of the telegram form, see 6.1.4
<ID> TT 00000	No telegram output	
<ID> TT 00001	Telegram VD spontaneous	Online output of telegram form, see 6.1.1
<ID> TT 00002	Telegram VDT spontaneous	Online output of telegram form, see 6.1.2
<ID> TT 00003	Telegram V4DT spontaneous	Online output of telegram form, to 6.1.3
<ID> TT 00004	Telegram NMEA V 2.0	Online output of telegram form, to 6.1.4

### Remark:

Due to the compatibility the telegrams VD and VDT supply the wind speed in 3 digits form  
In order to avoid that the measuring range is exceeded the telegrams deliver the wind speed exclusively in the unit of m/s (meters per second)!

## 10.2 Command Input

Please find your ID (identifier-number) in the works certificate included in the delivery.

For the input of commands and parameters please open first the access to the EEPROM by entering the command (ID) KY00001.

After all inputs have been made the access to the EEPROM should be locked again through the command (ID) KY00000 in order to avoid unauthorised changes of the system parameters.

The command is input by entering the instrument identification number (ID) followed by two letters which specify the actual command followed by a 5-digit code number respective value.

The characters are entered **without a space** and are **activated with Return**.

Entering the command without the 5-digit code number is interpreted as a query of the command status and leads to the output of the current command status.

**Correcting** the command word during input when an error has occurred is **not allowed** and the command will not be accepted.

**All letters** must be **capitalised**, otherwise they will not be accepted.

**Example:** Correcting an angle of displacement while setting up the anemometer by entering a corrective angle:

Instrument ID is accepted as 12. The necessary angular correction is 47°. The angle stored in the system up to that time was 15°. Attention: Input and representation in units of 1°.

The correction angle is added clockwise to the measured wind direction angle.

First opening of the EE-prom access:

Input: 12NC

System response: !12NC00015

Input: 12NC00047

System response: !12NC00047

Input into the system: 12KY00000

System response: protection

The system verifies the accepted input and displays the set value.

**Attention: After the supply voltage of the instrument has been switched on or switched off the locking is automatically activated.**

For **bus operation** in RS485 interface mode the permanent output of the measuring data must be stopped through the command **(ID)TT00000**. In addition, the echo operation for characters ES00000 must be switched off in order to avoid a bus conflict.

A single data telegram can then be called in through the command **(ID)TR0000(x)** in a telegram form described under item 6.1.

The „X“ in the command string means the selected telegram form (1, 2 or 3).

The ID-number selects the required instrument.

## 10.3 Factory setting (delivered versions) see supplementary sheet “Factory Settings”

## **11. Preparation for Use**

### **11.1 Selecting the Site**

As already described above the ultrasonic anemometer transmits sonic bursts which are necessary for the measurement of the propagation speed. If these sonic bursts hit a well sonic-reflecting surface they are reflected as echo and might cause error measurements – under unfavourable conditions.

It is, therefore, advisable to install the US-anemometer with a minimum distance of 1 meter to objects in the measurement area.

In general wind measurement instruments should be able to detect the wind conditions over a wide area. In order to obtain comparative values when determining the surface wind, measurements should be taken at a height of 10 meters above a plane, unobstructed area. An unobstructed area is one where the distance between the wind transmitter and any obstacle is at least 10 times greater than the height of the obstacle. (s. VDI (German Engineers Association) 3786). If this requirement cannot be fulfilled, then the wind measurement instrument should be set up at a height where the measured values are not influenced by any local obstacles (approx. 6-10 m above the level of the obstacle). The anemometer should be set up in the center of flat roofs, not at the edge in order to avoid possible preferred directions.

### **11.2 Mounting the wind transmitter**

The wind transmitter must be mounted to a pipe piece of R 1 ½" (Ø 48.3 mm) which is 50 mm long. The internal diameter of the pipe must be at least 40 mm as the wind transmitter is connected electrically from below with a plug. Solder a flexible control line LiYCY with the corresponding number of cores to the enclosed plug. After the wind transmitter has been connected, set it onto the pipe piece respectively the mast piece. The branch of the red marked sonic transducer must be aligned to North. To do this, take a bearing via the ultrasonic transducer of the North/South path onto an object to the North, for example a building or a special geographic feature. Use the four screws with hexagonal recessed holes (SW 4 mm) to attach the instrument to the shaft.

#### **Note :**

**The anemometer is used in vertical position.**

**Please make sure that no precipitation gets into the shaft or plug when mounting, de-mounting, transporting, or maintaining the anemometer.**

**When using a lightning rod please take care that it is mounted always in an angle of 45° to the measuring distance, as otherwise there might be deviations of measuring value.**

### **11.3 North Alignment**

For the alignment of the anemometer the **branch of the red marked sonic transducer must indicate to North**. For this, you select an obvious point in a northerly or southerly direction in the surroundings with the aid of a compass; then turn the mast or the anemometer into this direction until both arms opposite are situated in a straight line.

It is also possible that oneself stands in a northerly or southerly direction with respective distance, and a partner turns the anemometer or mast by command until both sensor arms are situated in a straight line.

In this case, it is advisable to use a pair of field glasses.

## 12. Maintenance

As the instrument has no moving parts i.e. operates without wear or tear, only minimal maintenance is required. As the sensor surface is permanently washed up by the falling rain it is only occasionally necessary to clean the surface with non-aggressive cleansing agent and soft cloth. These cleansing activities can be carried out – as far as necessary – on occasion of the routine checks.

### ATTENTION:

**Please make sure that no precipitation gets into the shaft or plug when storing, mounting, de-mounting, transporting, or maintaining the anemometer.**

## 13. Calibration

The ultrasonic anemometer does not contain any adjustable components such as electrical or mechanical trimming elements. All of the components and materials are invariant in time. Thus, regular calibration because of ageing is not required. Only a mechanical deformation of the transformer arms and the resulting changes in the length of the measurement paths lead to errors in the measured values.

The virtual temperature can be used to check the length of the measurement path. A change in the measurement path length of 0.17% and consequently a measurement error of 0.17% of the wind speed corresponds to a 1 K deviation of the virtual temperature at 20 °C, thus at 6 K deviation, the measurement error of wind speed is approx. 1%.

If the distance of measuring path of the anemometer is de-aligned please contact the producer for a re-calibration of the instrument.

## 14. Warranty

Damages resulting from improper handling or caused by external influences, e.g. lightning, are excluded from the warranty. The warranty expires if the instrument has been opened.

## 12. Accessories (Optional)

Connecting cable, complete	506 702	15 m cable with connecting plug
PC Software Meteo-Online	9.1700.98.000	For visualization of data on PC screen
Power Supply Unit	9.3388.00.000	For the power supply of the Ultrasonic
RS 232 / RS 422 converter	9.1702.20.000	For signal conversion of RS 422 in RS 232
Lightning Rod	4.3100.99.150	For lightning protection

### Attention :

**A return of the instruments must be effected in the original packing as otherwise the guarantee expires in case of mechanical damages e.g. by deformation of the transducer arms.**

	<b>ADOLF THIES GmbH &amp; Co. KG</b>		
	Hauptstraße 76 37083 Göttingen Germany P.O. Box 3536 + 3541 37025 Göttingen Phone ++551 79001-0 Fax ++551 79001-65 www.thiesclima.com info@thiesclima.com		

- Alterations reserved -