

## Instruction for Use

021150/04/08

---

# *Small Wind Transmitter*

4.3515.5x.xx0

4.3515.61.100



### **ADOLF THIES GmbH & Co. KG**

Hauptstraße 76

Box 3536 + 3541

Phone ++551 79001-0

[www.thiesclima.com](http://www.thiesclima.com)

37083 Göttingen Germany

37025 Göttingen

Fax ++551 79001-65

[info@thiesclima.com](mailto:info@thiesclima.com)

# **Contents**

|     |   |   |
|-----|---|---|
| 1   | Models available .....                                    | 3 |
| 2   | Application .....   | 3 |
| 3   | Construction and Mode of Operation .....                  | 3 |
| 4   | Recommendation Side Selection/Standard Installation ..... | 3 |
| 5   | Installation.....   | 4 |
| 5.1 | Mechanical Mounting .....                                 | 4 |
| 5.2 | Electrical Mounting .....                                 | 4 |
| 6   | Maintenance .....   | 5 |
| 7   | Connecting Diagram .....                                  | 5 |
| 8   | Technical Data.....                                       | 5 |
| 9   | Dimension diagram.....                                    | 6 |
| 10  | EC-Declaration of Conformity .....                        | 7 |

# 1 Models available

---

| Order-No.     | Meas. range   | Output                         | Heating | Connection  | Housing-colour |
|---------------|---------------|--------------------------------|---------|---|----------------|
| 4.3515.50.000 | 0.8... 40 m/s | typ. 2,3 Hz / ms <sup>-1</sup> | yes     | 3 m cable LiYY 4 x 0.25 mm <sup>2</sup>                   | white          |
| 4.3515.50.100 | 0.8... 40 m/s | typ. 2,3 Hz / ms <sup>-1</sup> | yes     | 3 m cable LiYY 4 x 0.25 mm <sup>2</sup>                   | black          |
| 4.3515.51.000 | 0.8... 40 m/s | typ. 2,3 Hz / ms <sup>-1</sup> | no      | 3 m cable LiYY 2 x 0.5 mm <sup>2</sup>                    | white          |
| 4.3515.51.100 | 0.8... 40 m/s | typ. 2,3 Hz / ms <sup>-1</sup> | no      | 3 m cable LiYY 2 x 0.5 mm <sup>2</sup>                    | black          |
| 4.3515.51.110 | 0.8... 40 m/s | typ. 2,3 Hz / ms <sup>-1</sup> | no      | 10 m cable LiYY 2 x 0,5 mm <sup>2</sup>                   | black          |
| 4.3515.61.100 | 0.8... 40 m/s | typ. 2,3 Hz / ms <sup>-1</sup> | no      | 3 m cable LiYY 2 x 0.22 mm <sup>2</sup> ,<br>UV-resistant | black          |

---

## 2 Application

---

The small wind transmitter is designed for the acquisition of the horizontal wind direction. The measuring value is output as frequency which is proportional to the wind speed. The measuring data available are ideally adapted to the supply in display instruments, recording instruments, datalogger, as well as process control systems.

For trouble-free winter operation the instrument is optionally equipped with a heating (PTC-heating element).

## 3 Construction and Mode of Operation

---

The outer parts of the instrument are made of plastic, the mounting angle is made of stainless steel. Labyrinth gaskets protect the parts inside the instrument against precipitation.

The cup star is set into rotation by the wind. An axis, running in friction bearings, is fixed at the cup star, and leads to magnets through a Reed-contact. The pulses thus produced are available as output signals.

## 4 Recommendation Side Selection/Standard Installation

---

In general wind measurement instruments should be able to detect the wind conditions of a large area. In order to obtain comparable values when determining the surface wind, measurements should be taken at a height of 10 meters over an even unobstructed area. An unobstructed area means that the distance between the wind transmitter and an obstacle should be at least 10 times the height of the obstacle ( s. VDI 3786 ). If it is not possible to fulfil this condition, then the wind transmitter should be set up a height where local obstacles do not influence the measured values to any significant extent (approx. 6-10 m above the obstacle).

The wind transmitter should be set up in the centre of flat roofs and not on the roof side in order to avoid bias in the direction (privileged directions).

## 5 Installation

---

### **Remark:**

When using fastening adapters (angle, traverses, brackets etc.) please take a possible effect by turbulences into consideration.

---

### **Attention:**

**Storing, mounting and operation under weather conditions is permissible only in vertical position, as otherwise water can get into the instrument.**

### 5.1 Mechanical Mounting

The wind transmitter is screwed onto a traverse, a mast etc. by means of a mounting angle. The cable is fixed tightly, for ex., onto the traverse, by means of clamps, cable ties, or similar fastenings.

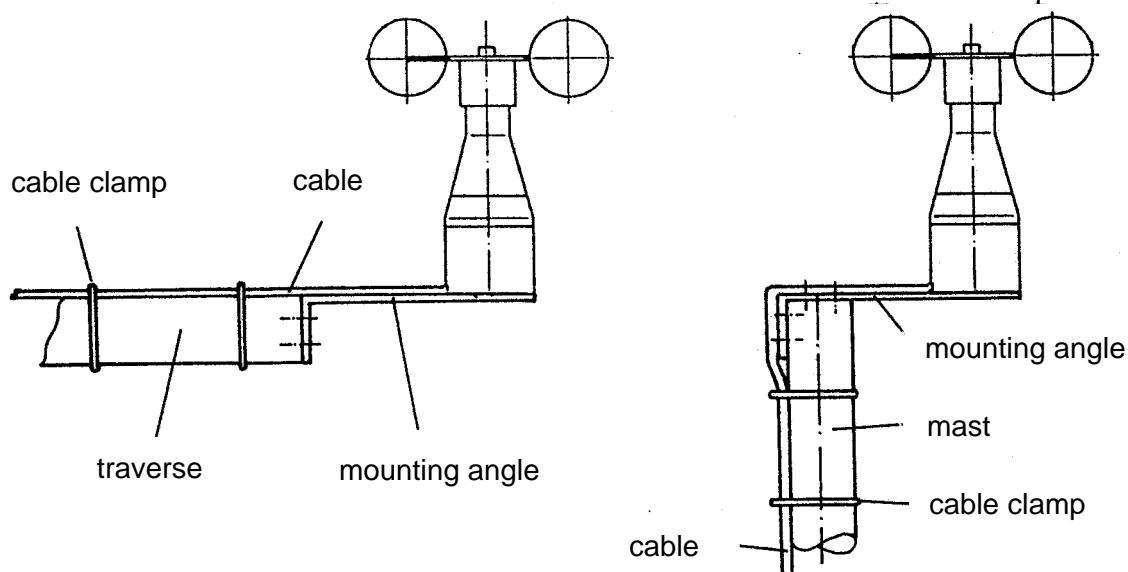

### 5.2 Electrical Mounting

The electrical connection is carried out acc. to the connection diagram (chapter 7).

## 6 Maintenance

After proper mounting the instruments works maintenance-free.  
Heavy pollution can clog up the slit between the rotating and the stationary parts of the wind transmitter. This slit must be kept clean

## 7 Connecting Diagram

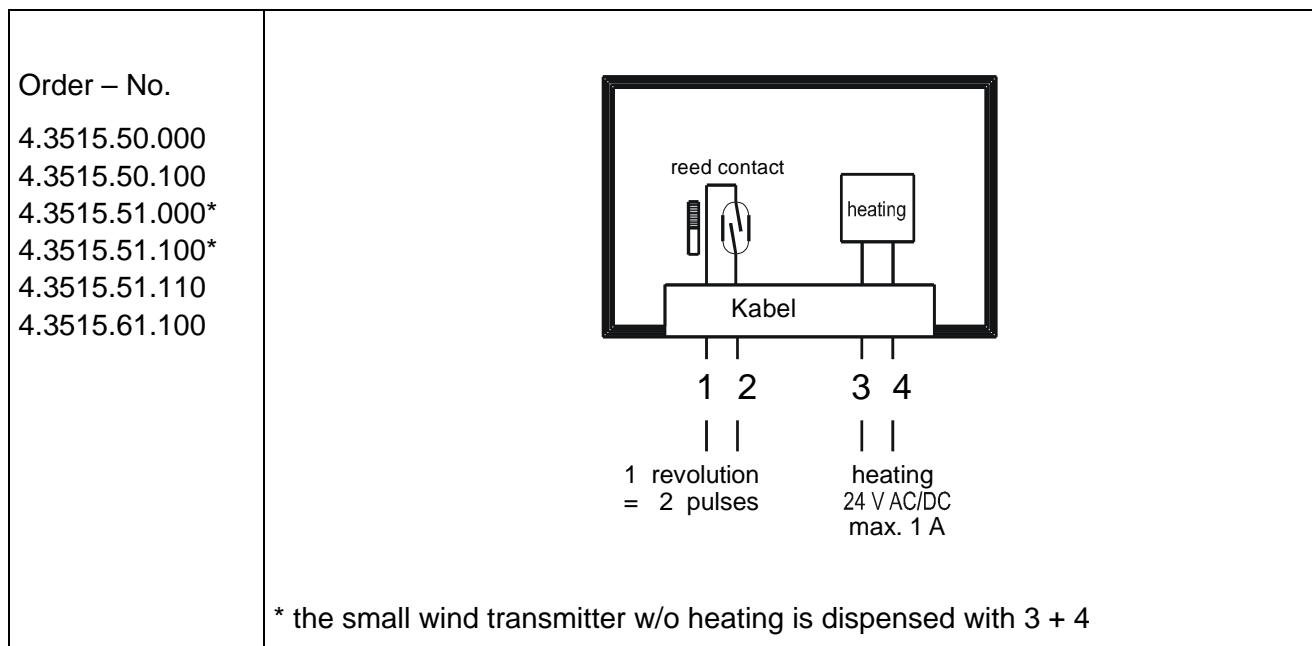

## 8 Technical Data

|                             |   |
|-----------------------------|---|
| Measuring range             | 0.8 ... 40 m/s                                |
| Electrical output           | typ. 2,3 Hz / ms <sup>-1</sup>                |
| Resolution                  | 0.4 m wind run                                |
| Accuracy                    | ± 0.5 m/s or ± 5% of measuring value          |
| Measuring system            | 1 x Reed-contact, 2 x magnet                  |
| Contact                     | Reed-contact                                  |
| Contact load (Reed-contact) | 10 VA, max. 42 V DC, max. 0.4 A               |
| Load                        | max. 60 m/s for a short time                  |
| heating                     | 24 V AC / DC (80 °C)                          |
| Switch-on current           | max. 1 A                                      |
| Ambient temperature         | - 25 °C ... + 60 °C (with ice-free condition) |
| Material                    | plastic ABS                                   |
| Connection                  | See models available                          |
| Dimensions                  | See dimensional diagram                       |
| Weight                      | 0.3 kg  |

## 9 Dimension diagram

---

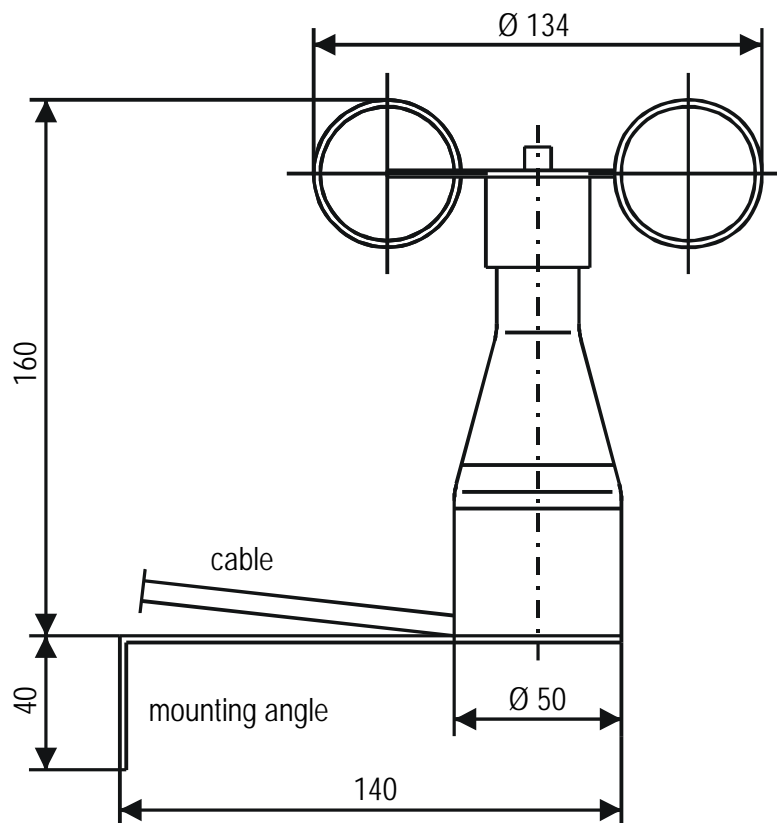

# 10 EC-Declaration of Conformity

Document-No.: 000410

Month: 06 Year: 08

Manufacturer: **ADOLF THIES GmbH & Co. KG**

Hauptstr. 76  
D-37083 Göttingen  
Tel.: (0551) 79001-0  
Fax: (0551) 79001-65  
email: Info@ThiesClima.com

Description of Product: **Small Wind Transmitter, Photo Wind Transmitter**

|             |                      |                      |                       |                      |
|-------------|----------------------|----------------------|-----------------------|----------------------|
| Article No. | <b>4.3400.30.000</b> | <b>4.3515.30.000</b> | <b>4.3515.30.000A</b> | <b>4.3515.30.001</b> |
|             | <b>4.3515.30.002</b> | <b>4.3515.30.030</b> | <b>4.3515.30.036</b>  | <b>4.3515.30.900</b> |
|             | <b>4.3515.50.000</b> | <b>4.3515.50.061</b> | <b>4.3515.50.100</b>  | <b>4.3515.50.161</b> |
|             | <b>4.3515.51.000</b> | <b>4.3515.51.061</b> | <b>4.3515.51.100</b>  | <b>4.3515.51.110</b> |
|             | <b>4.3515.51.161</b> | <b>4.3515.51.361</b> | <b>4.3515.51.961</b>  | <b>4.3515.61.100</b> |
|             | <b>4.3517.30.000</b> | <b>4.3517.30.010</b> | <b>4.3517.30.020</b>  | <b>4.3517.31.000</b> |
|             | <b>4.3517.51.000</b> | <b>4.3517.60.010</b> | <b>4.3517.71.000</b>  | <b>4.3711.30.000</b> |

specified technical data in the document: **020917/02/97; 020760/08/04; 020743/04/08; 021125/10/06; 021543/08/07**

The indicated products correspond to the essential requirement of the following European Directives and Regulations:

- 2004/108/EC DIRECTIVE 2004/108/EC OF THE EUROPEAN PARLIAMENT AND OF THE COUNCIL of 15 December 2004 on the approximation of the laws of the Member States relating to electromagnetic compatibility and repealing Directive 89/336/EEC
- 2006/95/EC DIRECTIVE 2006/95/EC OF THE EUROPEAN PARLIAMENT AND OF THE COUNCIL of 12 December 2006 on the harmonisation of the laws of Member States relating to electrical equipment designed for use within certain voltage limits
- 552/2004/EC Regulation (EC) No 552/2004 of the European Parliament and the Council of 10 March 2004 on the interoperability of the European Air Traffic Management network (the interoperability Regulation)

The indicated products comply with the regulations of the directives. This is proved by the compliance with the following standards:

| Reference number    | Specification  |
|---------------------|--|
| IEC 61000-6-2: 2005 | Electromagnetic compatibility<br>Immunity for industrial environment   |
| IEC 61000-6-3: 2006 | Electromagnetic compatibility<br>Emission standard for residential, commercial and light industrial environments       |
| IEC 61010-1: 2001   | Safety requirements for electrical equipment for measurement, control and laboratory use. Part 1: General requirements |

Place: Göttingen

Date: 30.06.2008

Legally binding signature:

issuer:

.....  
Wolfgang Behrens, General Manager

.....  
Joachim Beinhorn, Development Manager

This declaration certifies the compliance with the mentioned directives, however does not include any warranty of characteristics. Please pay attention to the security advises of the provided instructions for use.



## **ADOLF THIES GmbH & Co. KG**

Hauptstraße 76      37083 Göttingen Germany  
P.O. Box 3536 + 3541      37025 Göttingen  
Phone ++551 79001-0      Fax ++551 79001-65  
[www.thiesclima.com](http://www.thiesclima.com)      [info@thiesclima.com](mailto:info@thiesclima.com)



- Alterations reserved -