

Instruction for Use

021519/01/09

Wind Transmitter „First Class“ Advanced

Classified according to IEC 61400-12-1 (2005-12)

4.3351.00.000

4.3351.10.000



ADOLF THIES GmbH & Co. KG

Hauptstraße 76

Box 3536 + 3541

Phone ++551 79001-0

www.thiesclima.com

37083 Göttingen Germany

37025 Göttingen

Fax ++551 79001-65

info@thiesclima.com

Contents

1	Models available	2
2	Application	3
3	Construction and Mode of Operation	3
4	Recommendation Side Selection / Standard Installation	4
5	Installation.....	4
5.1	Electrical Mounting	4
5.2	Mechanical Mounting	4
6	Plug Mounting	5
7	Maintenance	5
8	Connecting Diagram	6
9	Technical Data.....	7
10	Dimensional Drawing.....	8
11	Accessories	9
12	EC-Declaration of Conformity	10

Patent

Patent Nr.: EP 1 398 637

Patent Nr.: DE 103 27 632

Patent Nr.: EP 1 489 427

1 Models available

Order - No.	Meas. range	Output Frequency	Supply	Heating
4.3351.00.000	0.3...75 m/s	1082 Hz @ 50 m/s	3.3 - 42 V DC	24V AC/DC, 25 W
4.3351.10.000	0.3...75 m/s	1082 Hz @ 50 m/s	3.3 - 42 V DC	w/o heating

The following parts are included in delivery:

- 1 Instrument
- 1 Terminal plug
- 1 Instruction for Use

2 Application

The wind transmitter is designed for the acquisition of the horizontal component of the wind speed in the field of meteorology and environmental measuring technology, evaluation of location, and measurement of capacity characteristics of wind power systems

Special characters are defined and optimised, dynamic behaviour also at high turbulence intensity, minimal over-speeding, and a low starting values.

The measuring value is available as digital signal at the output. It can be transmitted to display instruments, recording instruments, data loggers as well as to process control systems. For winter operation the instrument is optional equipped with an electronically regulated heating, which guarantees a smooth running of the ball bearings, and prevents the shaft and slot from icing-up.

Remark

When using fastening adapters (angle, traverses, etc) please take a possible effect to the measuring values by shading into consideration.

3 Construction and Mode of Operation

A low-inertia cup star with 3 cups, made of carbon-fibre-reinforced plastic, is set into rotation by the wind. The rotation is scanned opto-electronically, and is converted into a square wave signal. The frequency of this signal is proportional to the number of rotations. Depending on the supply voltage, the output signal ranges between maximal output voltage and ground or a potential (life-zero), lifted by approx. 1,2 V. The supply of the electronics can be done by DC-voltage of 3,3 V up to 42 V at a very low current consumption. An AC- or DC-voltage of 24 V is intended for the separate supply of the optional heating. In all probability, the heating guarantees a trouble-free function of the Wind Transmitter First Class even under extreme meteorological icing-conditions.

The outer parts of the instrument are made of corrosion-resistant anodised aluminium. Highly effective labyrinth gaskets and O-rings protect the sensitive parts inside the instrument against humidity and dust. The instrument is mounted onto a mast tube; the electrical plug-connection is located in the transmitter shaft.

4 Recommendation Side Selection / Standard Installation

In general, wind measuring instruments are supposed to record wind conditions over a large area. According to international regulations, the surface wind should be measured at a height of 10 m above even open terrain, in order to achieve comparable values. An open terrain is defined as terrain where the distance between the wind-measuring instrument and the next obstacle is at least ten times the height of this obstacle (Guide to Meteorological Instruments and Methods of Observation, Sixth Edition, WMO-No. 8). If this regulation cannot be fulfilled, the measuring instrument should be installed at a height at where the measurement values are not influenced by any local obstacles. In any case, the measuring instruments should be installed at a height of 6 to 10 m above the mean height of the buildings or trees in the vicinity. If it is necessary to install the instrument on a roof, it should be installed in the centre of the roof in order to avoid any preferential directions.

5 Installation

5.1 Electrical Mounting

Solder a shielded cable with diameter 7-8 mm and a core cross-section of 0,5...0,75 mm² to the enclosed coupling socket.

- The number of necessary wires is given in the connection diagram (chapter 8).

Cable recommendation	
Type/ No. of cores /Diameter	Cable diameter
LIYCY 4 x 0.75 mm ²	ca. 7 mm
LIYCY 5 x 0.50 mm ²	ca. 7 mm
LIYCY 6 x 0.75 mm ²	ca. 7.7 mm
LIYCY 7 x 0.50 mm ²	ca. 7.5 mm
LIYCY 8 x 0.50 mm ²	ca. 8 mm

5.2 Mechanical Mounting

Mount the transmitter onto a pipe socket of R 1" (Ø 33.5 mm) and a length of 25 mm. The pipe socket must have an internal diameter of at least 25 mm as the wind transmitter must be connected electrically with a plug from below.

After electrical connection the wind transmitter is put onto the pipe socket, and is fixed by means of 2 threaded pins (female hexagon 3 mm) at the base of the transmitter.

Attention

Storing, mounting, and operation under weather conditions is permissible only in vertical position, as otherwise water can get into the instrument.

6 Plug Mounting

Coupling socket 507550 (Binder, Serial 423), EMC with cable clamp

<ol style="list-style-type: none"> 1. Stringing parts on cable acc. to plan given above. 2. Stripping cable sheath 20 mm Cutting uncovered shield 15 mm Stripping wire 5mm. <p><i>Cable mounting 1</i> Putting shrink hose or insulating tape between wire and shield.</p> <p><i>Cable mounting 2</i> If cable diameter permits, put the shield backward on the cable sheath.</p> <ol style="list-style-type: none"> 3. Soldering wire to the insert, positioning shield in cable clamp. 4. Screwing-on cable clamp. 5. Assembling remaining parts acc. to upper plan. 6. Tightening pull-relief of cable by screw-wrench (SW16 und 17). 	<p><i>Cable mounting 1</i> View X</p> <p><i>Cable mounting 2</i> View X</p>

7 Maintenance

If properly installed, the instrument requires no maintenance. Heavy pollution can lead to blockage of the slot between the rotating and the stable parts of the transmitter. Thus it is advisable to remove the accumulated dirt from the instrument .

Certain symptoms of wear and tear can appear on the ball bearings after years of use. These symptoms are expressed in a lowered sensitivity of response, standstill or run-noises of the ball bearings. In case that such disturbances might occur we recommend to return the instrument - in original package – to the factory for maintenance work.

Remark

For transport of instrument please use original packing.

8 Connecting Diagram

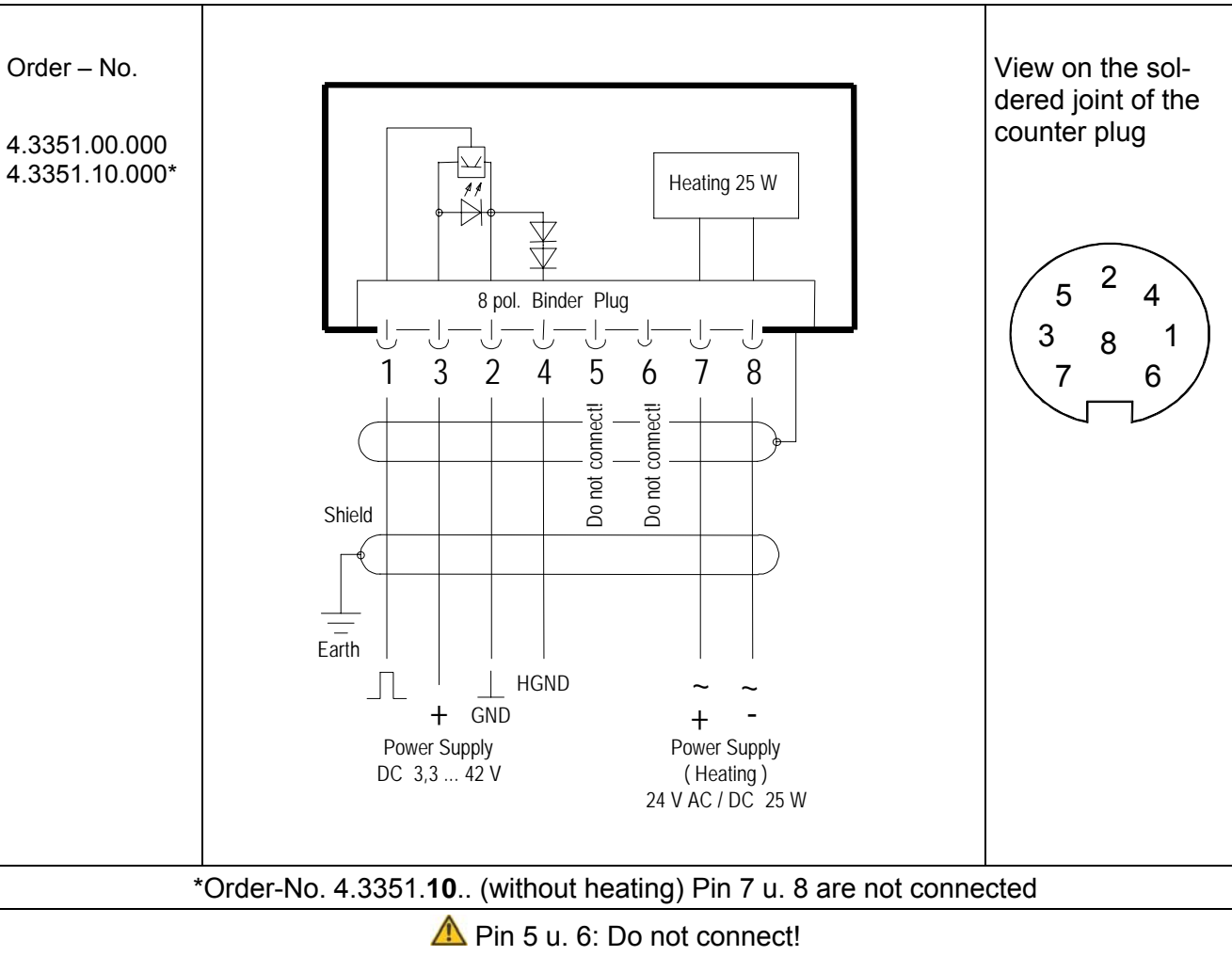

Pin	Name	Function
1	SIG	Signal (rectangle)
2	GND	Ground
3	+Us	Supply 3.3 V - 42 V DC
4	HGND	Ground at life-zero signal
5	⚠	Do not connect!
6	⚠	Do not connect!
7	HZG	Heating supply: voltage: 24 V AC/DC power: 25 W
8	HZG	

*Order-No. 4.3351.10.. (without heating) PIN 7 u. 8 are not connected

9 Technical Data

Characteristic	Description
Measuring range	0.3...75 m/s
Accuracy	0.3...50 m/s 1% of meas. value or < 0.2 m/s
Survival speed	80 m/s (min. 30 minutes)
Permissible Ambient conditions	- 50...+ 80°C, all occurring situations of relative humidity (incl. dew moistening)
Output signal	Form rectangle Frequency 1082 Hz @ 50 m/s Amplitude is supply voltage, max. 15 V Load R > 1 kΩ (Push-pull output with 220 Ω in series) C < 200 nF (corresp. to length typical cable < 1km)
Linearity	Correlation factor r between frequency and wind speed $y=0,0462 \cdot f + 0,21$ typical $r > 0.99999$ (4...20 m/s)
Starting velocity	< 0.3 m/s
Resolution	0.05 m wind run
Distance constant	< 3 m (acc. to ASTM D 5096 – 96) 3 m acc. to ISO 17713-1
Turbulent flow	Deviation Δv turbulent compared with stationary horizontal flow $-0.5\% < \Delta v < +2\%$ Frequency < 2 Hz
Classification	According to IEC 61400-12-1 (2005-12) Class A classification index A 0,9 Class B classification index B 3,0 Class S classification index S 0,5
Wind load	Approx.. 100 N @ 75 m/s
Heating	Surface temperature of housing neck > 0 °C at 20 m/s up to –10 °C air temperature, at 10 m/s up to –20 °C using the THIES icing standard 012002 on the housing neck. Heating regulated by temperature sensor
Electrical supply for opto-electronic scanning	Voltage: 3.3 - 42 V DC (galvanic isolation from housing) current: 0.3 ma @ 3.3 V typical (w/o external load) < 0.5 ma @ 5 V (w/o external load)
Electrical supply for heating	Voltage: 24 V AC/DC (galvanic isolation from housing) Idling voltage: max. 30 V AC, max. 42 V DC Capacity: 25 W
Connection	8-pole plug-connection for shielded cable in the shaft (see connecting diagram)
Mounting	Mounting on mast R 1", for ex. DIN 2441

	1½ " with separate adaptor (option)
Dimensions	See dimension diagram
Weight	approx. 0.5 kg
Protection	IP 55 (DIN 40050)
EMC	EN 61000-6-2:2001 (immunity) EN 55022:2001, class B (interfering transmission)

10 Dimensional Drawing

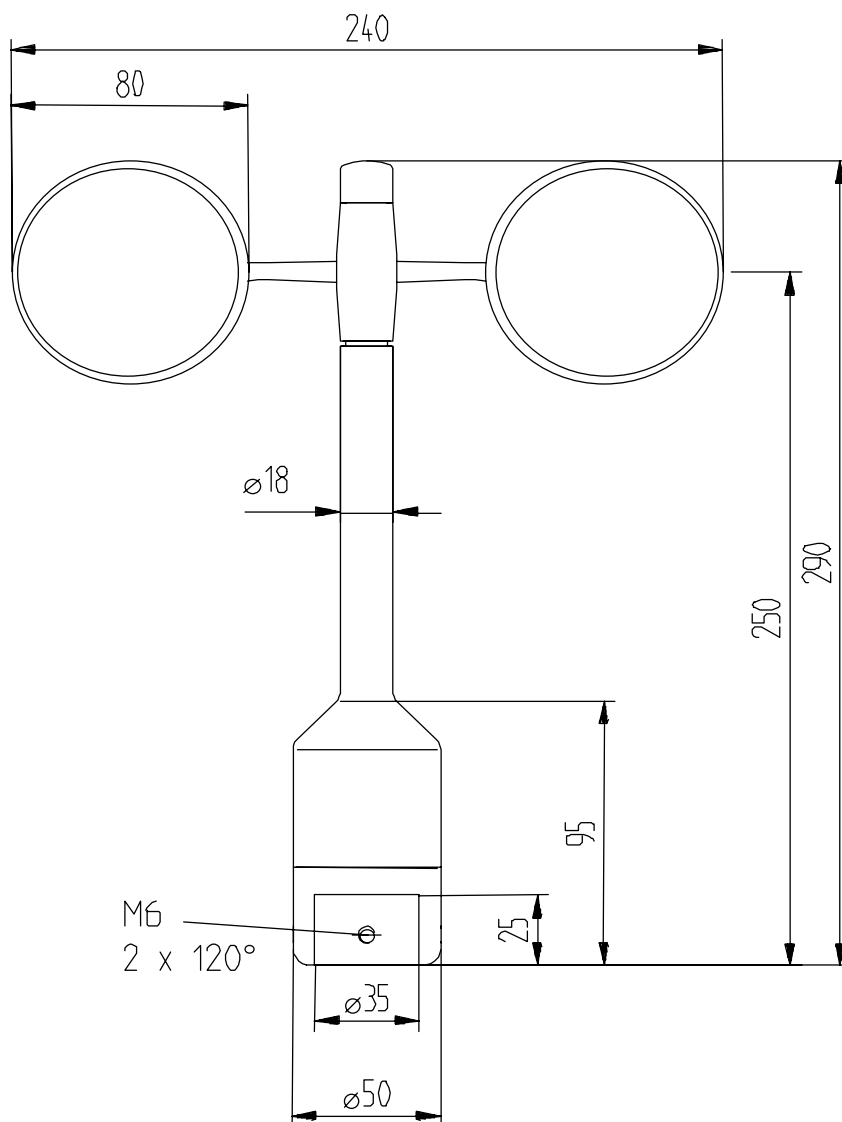

11 Accessories

The following accessories are available for the wind direction transmitter:

Traverse 0,6 m For mounting the wind speed and wind direction transmitter jointly onto a mast	4.3174.00.000	Horizontal sensor distance: 0.6 m Vertical sensor distance: 0.2 m Mast receptacle: 48 - 50 mm Material: Aluminum, anodised Dimensions: tube Ø 34x4mm, 668 mm long, 756 mm high
--	---------------	--

Hanger –FIRST CLASS- 1m For the lateral mounting of a wind speed and wind direction transmitter onto a mast..	4.3184.01.000	Sensor distance to mast: 1 m Mast clamp: 40 – 80 mm Tube diameter: 34 mm Material: Aluminum
---	---------------	--

Lightning rod For mounting the a/m traverse or hanger.	4.3100.98.000	Dimension: Ø 12 mm, 500 mm long, 1050 mm high Material: Aluminum
---	---------------	---

Please contact us for other accessories such as cables, power supply units, masts, as well as for additional mast- or system-constructions.

Example: Wind transmitter with traverse 4.3174.00.000 and lightning rod 4.3100.98.000.



12 EC-Declaration of Conformity

Document-No.: **001574**

Month: 01 Year: 09

Manufacturer: **ADOLF THIES GmbH & Co. KG**

Hauptstr. 76
D-37083 Göttingen
Tel.: (0551) 79001-0
Fax: (0551) 79001-65
email: Info@ThiesClima.com

Description of Product: **Windsensor FIRST CLASS**

Article No.	4.3350.00.000	4.3350.10.000	
	4.3350.00.140	4.3350.00.141	4.3350.00.161
	4.3350.10.140	4.3350.10.141	4.3350.10.161
	4.3351.00.000	4.3351.10.000	
	4.3351.00.140	4.3351.00.141	4.3351.00.161
	4.3351.10.140	4.3351.10.141	4.3351.10.161

specified technical data in the document: **021309/07/06; 021435/01/07; 021518/01/09; 021548/01/09**

The indicated products correspond to the essential requirement of the following European Directives and Regulations:

2004/108/EC	DIRECTIVE 2004/108/EC OF THE EUROPEAN PARLIAMENT AND OF THE COUNCIL of 15 December 2004 on the approximation of the laws of the Member States relating to electromagnetic compatibility and repealing Directive 89/336/EEC
2006/95/EC	DIRECTIVE 2006/95/EC OF THE EUROPEAN PARLIAMENT AND OF THE COUNCIL of 12 December 2006 on the harmonisation of the laws of Member States relating to electrical equipment designed for use within certain voltage limits
552/2004/EC	Regulation (EC) No 552/2004 of the European Parliament and the Council of 10 March 2004 on the interoperability of the European Air Traffic Management network (the interoperability Regulation)

The indicated products comply with the regulations of the directives. This is proved by the compliance with the following standards:

Reference number	Specification
IEC 61000-6-2: 2005	Electromagnetic compatibility Immunity for industrial environment
IEC 61000-6-3: 2006	Electromagnetic compatibility Emission standard for residential, commercial and light industrial environments
IEC 61010-1: 2001	Safety requirements for electrical equipment for measurement, control and laboratory use. Part 1: General requirement

Place: Göttingen

Date: 22.01.2009

Legally binding signature:

issuer:

.....
Wolfgang Behrens, General Manager

.....
Joachim Beinhorn, Development Manager

This declaration certifies the compliance with the mentioned directives, however does not include any warranty of characteristics. Please pay attention to the security advises of the provided instructions for use.



ADOLF THIES GmbH & Co. KG

Hauptstraße 76 37083 Göttingen Germany
P.O. Box 3536 + 3541 37025 Göttingen
Phone ++551 79001-0 Fax ++551 79001-65
www.thiesclima.com info@thiesclima.com



- Alterations reserved -