

Instruction for Use

020918/10/07

Combined Wind Transmitter

Output: 8 Bit parallel

4.3324.31.000 / 001



ADOLF THIES GmbH & Co. KG

Hauptstraße 76

Box 3536 + 3541

Phone ++551 79001-0

www.thiesclima.com

37083 Göttingen Germany

37025 Göttingen

Fax ++551 79001-65

info@thiesclima.com

Contents

1	Models available	2
2	Application	2
3	Construction and Mode of Operation	3
4	Recommendation Side Selection/ Standard Installation	3
5	Installation.....	4
5.1	Mounting the Cup Star	4
5.2	Mounting the Wind Vane	5
5.3	Mounting of Wind Transmitter	5
5.4	Electrical Mounting	6
6	Maintenance	6
	Connecting Diagrams.....	6
8	Technical Data.....	7
9	Dimensional Drawings	8
10	EC-Declaration of Conformity	10

Figures

Figure 1: Dimension 4.3324.x1.000.....	8
Figure 2: Dimension 4.3324.x1.001 / 008.....	9

1 Models available

Order-No.	Measuring range	Electrical Output	Model
4.3324.31.000	WG 0,3 ... 50 m/s WR 0 ... 360°	3 ... 1042 Hz (with Offset) 8 Bit parallel (with Offset)	Standard version
4.3324.31.001	WG 0,3 ... 50 m/s WR 0 ... 360°	3 ... 1042 Hz (with Offset) 8 Bit parallel (with Offset)	Ship version* (short wind vane, reinforced cup star, special ball bearing)

* Comb. Wind transmitters for heavy mechanical load, for ex. on ships, wind power plants or the like.

The combined wind transmitters are shipped in semi-mounted state, in order to avoid transport damages and to keep the package small.

The following parts are included in delivery:

- 1 x combined wind transmitter, pre-mounted
- 1 x cup star
- 1 x wind vane
- 1 x connecting plug

2 Application

The combined wind transmitter serves for the acquisition of the horizontal components of the wind speed and the wind direction. All measuring values are available at the outputs analogue signals. They can be output to THIES-display instruments, and systems or for further processing.

For winter operation the instruments are equipped with an electronically regulated heating in order to guarantee a smooth running of the ball bearings, and to avoid ice-formation at the slot of the outer rotation parts. The electrical supply of wind transmitter heating is carried out, for ex., by our power supply unit, order-no. 9.3388.00.000.

3 Construction and Mode of Operation

The housing, cup star and wind vane are made of aluminum, die the surfaces are anodized. The bow consists of stainless steel. Labyrinth seals and o-rings protect the sensitive internal parts from precipitation. The instrument is designed for mounting to a mast tube; the electrical plug connection is situated in the transmitter shaft.

A low-inertia light-metal cup star (in ball bearings) is set into rotation by the wind. A pulse frequency is available at the output through the opto-electronic revolution-scanning.

The light-metal wind vane (in ball bearings) is moved by the wind. The measuring system consists of an opto-electronically operating absolute angle encoder. The measurement of angle is carried out automatically. During the automatic measurement operation the angle is updated at the 8-bit output approx. every 50 ms.

4 Recommendation Side Selection/ Standard Installation

In general wind measurement instruments should be able to detect the wind conditions of a large area. In order to obtain comparable values when determining the surface wind, measurements should be taken at a height of 10 meters over an even unobstructed area. An unobstructed area means that the distance between the wind transmitter and an obstacle should be at least 10 times the height of the obstacle (s. VDI 3786). If it is not possible to fulfil this condition, then the wind transmitter should be set up a height where local obstacles do not influence the measured values to any significant extent (approx. 6-10 m above the obstacle).

The wind transmitter should be set up in the centre of flat roofs and not on the roof side in order to avoid bias in the direction (privileged directions)..

5 Installation

Attention:

Storing, mounting and operation under weather conditions is permissible only in vertical position, as otherwise water can get into the instrument.

Remark:

When using fastening adapters (angle, traverses, hangers etc.) please take a possible effect by turbulences into consideration.

Remark:

*It is advisable to attach lightning rod, order no. **4.3100.99.000** in areas with considerable lightning activity.*

5.1 Mounting the Cup Star

Unscrew the cap nut (SW 8) from the wind velocity sensor case and remove the disk. Keep the rubber sealing washer in the protection cap. Set the cup star into position in such a way that the dowel pin in the cup star catches in the nut of the protective cap. Replace the disk and re-screw the cap nut. Hold the transmitter on the protective cap not on the cup.

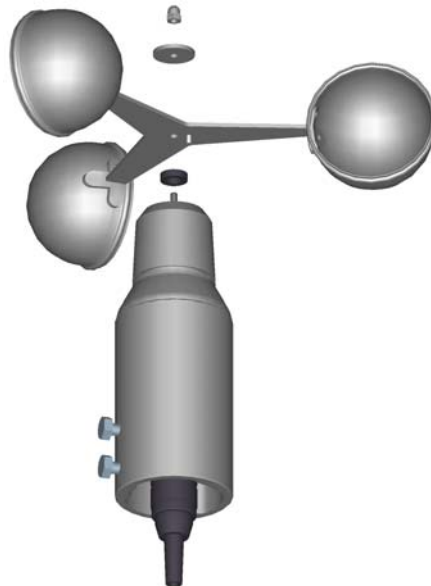

5.2 Mounting the Wind Vane

The wind vane is mounted in the same way as the cup star (s. 5.1), only without disc.

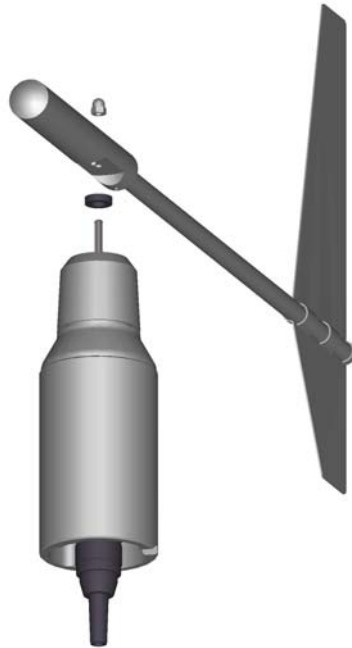

5.3 Mounting of Wind Transmitter

The transmitter can be mounted onto a tube of R 1 1/2" (\varnothing 48,3 mm), 50 mm long. The internal diameter of the mounting tube must be at least 40 mm since the transmitter will be plugged into an electrical system from below. Solder a cable (for ex. LiYCY) with the required number of leads of each 0,5 mm² onto the enclosed plug. After electrical connection, set the wind transmitter onto the tube. North marking and bow shall indicate to the North.

North Alignment

Rotate the case markings (north marking) on the shaft and on the protective cap until they are aligned. Then select an obvious point in a northerly direction in the surroundings (a tree, a building etc.) with the aid of a compass. Take a bearing on this point over the wind vane and the counter weight of the wind direction transmitter, and when these coincide screw the wind transmitter into place. (the north marking must indicate to the *geographic north*).

The instrument is fixed on the shaft by means of the two hexagon head screws.

Alignment of the comb. Wind Transmitter on a Ship

- The reference point for the wind transmitter is the roll-axis of the ship, whereat "0°" is related to the **ship bow**.

Rotate the case markings (north marking) on the shaft and on the protective cap until they are aligned. Take a bearing on ship bow over the wind vane and the counter weight of the wind direction transmitter, and when these coincide screw the wind transmitter into place. (the north marking must indicate to the *geographic north*).

- When aligning the comb. wind transmitter on other mobile objects (for ex. vehicles, wind power plants etc.) this procedure can be adopted

5.4 Electrical Mounting

For electrical connection please refer to the connecting diagram.

6 Maintenance

After proper mounting the instrument works maintenance free.

Heavy pollution can clog up the slit between the rotating and the stationary parts of the wind transmitter. This slit must be kept clean.

Remark:

Please use only original packing for transporting the instrument.

Connecting Diagrams

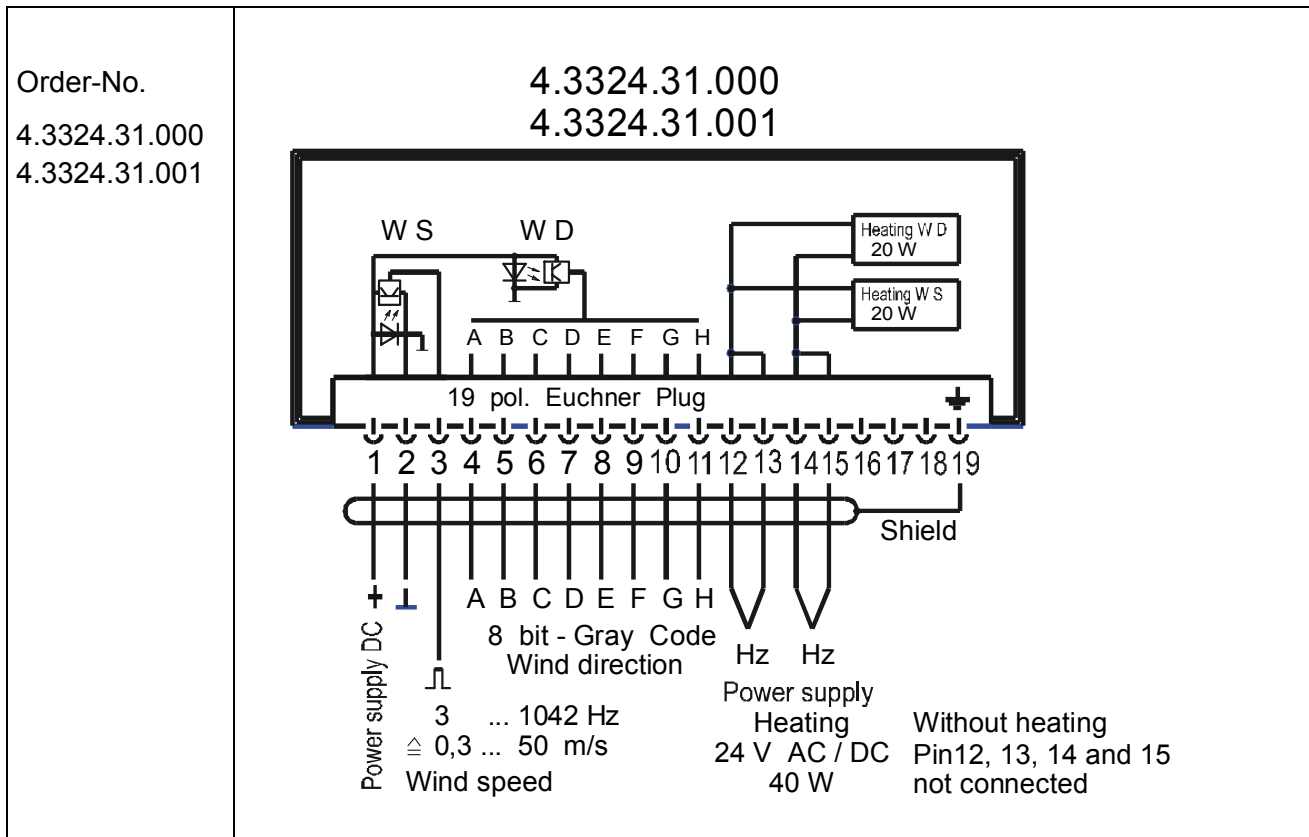

8 Technical Data

	Wind Speed	Wind Direction
Measuring range	0,3 ... 50 m/s	0 ... 360°
Start-up (with 4.3324.31.000)	0,3 m/s	<0,6 m/s at 90° vane move
Start-up (with 4.3324.31.001)	0,3 m/s	<1 m/s at 90° vane move
Accuracy	±0,3 m/s resp. 2 % of meas. value	±1,5°
Resolution	0,05 m wind run	2,5°
Distance constant	5 m	-----
Damping ratio	-----	0,2 –0,3
Electr. output	3 ... 1042 Hz	8 bit parallel (Code)
Voltage supply (U _B)	5 ... 18 V DC	5 ... 18 V DC
Output signal, unloaded	U _L ≈ 1 V / U _H ≈ U _B	U _L ≈ 0.7V / U _H ≈ U _B
Output signal, loaded	< 5 mA	< 10 mA
Current consumption (unloaded)	< 2.5 mA (U _B = 15 V)	< 2 mA (U _B = 15 V)

General

Max. wind load	60 m/s
Heating	24 V DC/AC, approx. 40 W, electronically regulated
Ambient temperature	-35...+80°C
Protection	IP 55
Wind load at 35 m/s	approx. 50 N
Mounting	onto mast tube 1 ½“, for ex. DIN 2441
Connection	19-pole plug connection in the shaft
Weight	3,4 kg

9 Dimensional Drawings

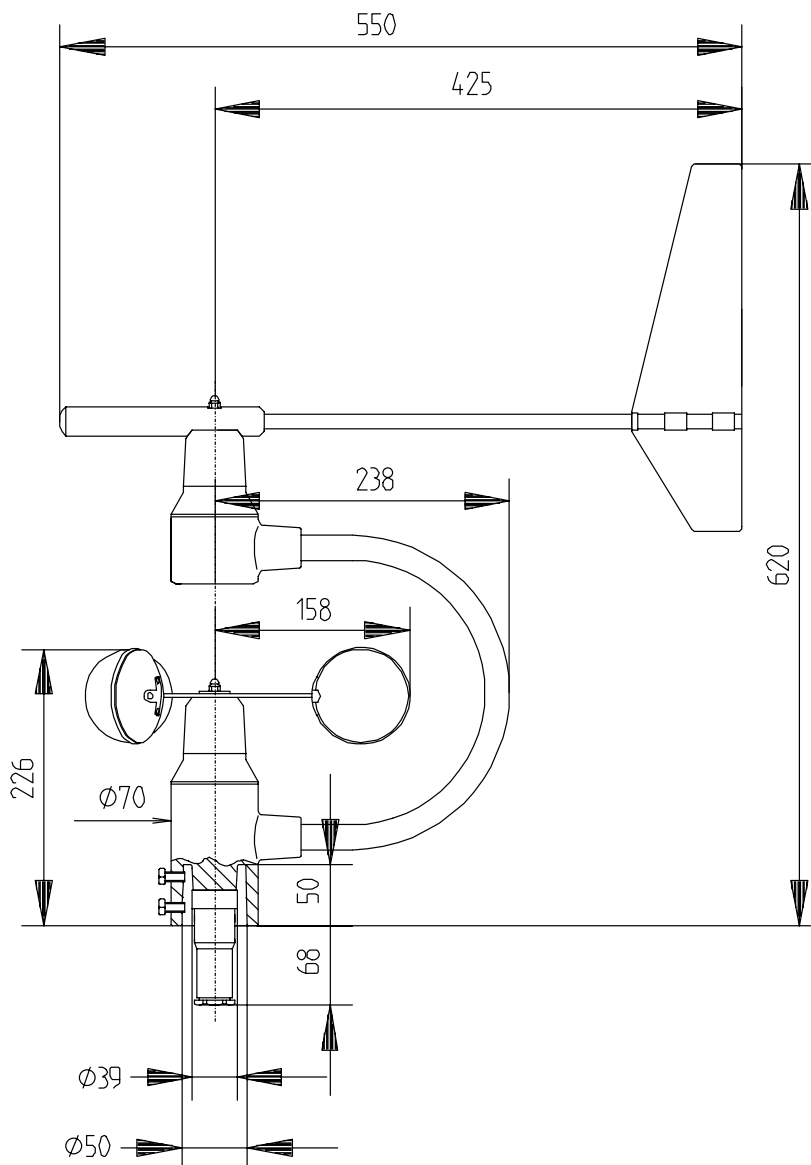

Figure 1: Dimension 4.3324.x1.000

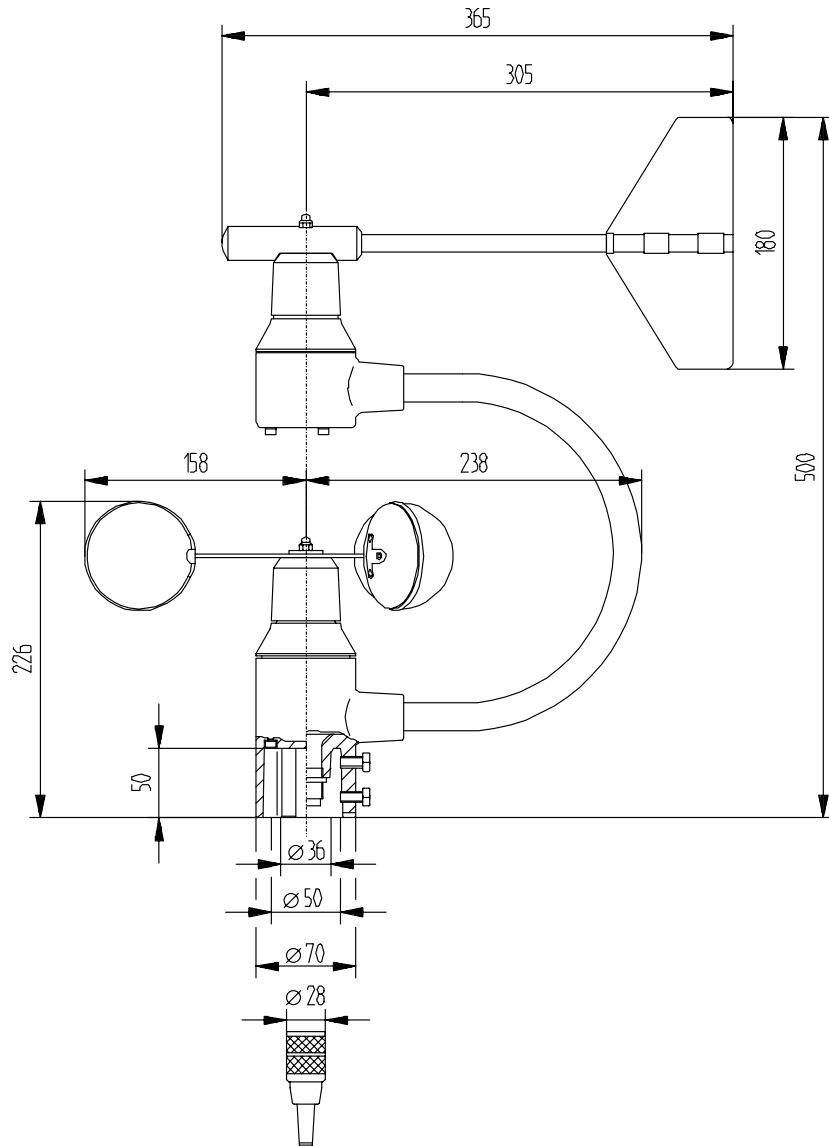

Figure 2: Dimension 4.3324.x1.001 / 008

10 EC-Declaration of Conformity

Document-No.: 001576

Month: 11 Year: 07

Manufacturer: **ADOLF THIES GmbH & Co. KG**

Hauptstr. 76
D-37083 Göttingen
Tel.: (0551) 79001-0
Fax: (0551) 79001-65
email: Info@ThiesClima.com

Description of Product: **Combined Wind Transmitter**

Article No.	4.3324.31.000	4.3324.31.001	4.3336.21.000	4.3336.21.001
	4.3336.21.008	4.3336.31.000	4.3336.31.001	4.3336.31.008

specified technical data in the document: **020907/10/07; 021460/10/07**

The indicated products correspond to the essential requirement of the following European Directives and Regulations:

- 89/336/EEC COUNCIL DIRECTIVE of 3 May 1989 on the approximation of the laws of the Member States relating to electromagnetic compatibility (89/336/EEC)
- 73/23/EEC COUNCIL DIRECTIVE of 19. Feb. 1973 on the harmonization of the law of Member States relating to electrical equipment designed for use within certain voltage limits (73/23/EEC)
- 552/2004/EC Regulation (EC) No 552/2004 of the European Parliament and the Council of 10 March 2004 on the interoperability of the European Air Traffic Management network (the interoperability Regulation)

The indicated products comply with the regulations of the directives. This is proved by the compliance with the following standards:

Reference number	Specification
EN61000-6-2:2002	Electromagnetic compatibility Immunity for industrial environment
EN61000-6-3:2002	Electromagnetic compatibility Emission standard for residential, commercial and light industrial environments
EN61010-1:2001	Safety requirements for electrical equipment for measurement, control and laboratory use. Part 1: General requirements

Place: Göttingen
Legally binding signature:

Wolfgang Behrens

Date: 16.11.2007
issuer:

Joachim Beinhorn

This declaration certifies the compliance with the mentioned directives, however does not include any warranty of characteristics. Please pay attention to the security advises of the provided instructions for use.



ADOLF THIES GmbH & Co. KG

Hauptstraße 76 37083 Göttingen Germany
P.O. Box 3536 + 3541 37025 Göttingen
Phone ++551 79001-0 Fax ++551 79001-65
www.thiesclima.com info@thiesclima.com



- Alterations reserved -