

## Instruction for Use

021488/06/09

### ***Wind Direction Transmitter - compact***

- GMR, analogue output -

**4.3129.60.xxx**

**4.3129.80.xxx**



### **ADOLF THIES GmbH & Co. KG**

Hauptstraße 76

Box 3536 + 3541

Phone ++551 79001-0

[www.thiesclima.com](http://www.thiesclima.com)

37083 Göttingen Germany

37025 Göttingen

Fax ++551 79001-65

[info@thiesclima.com](mailto:info@thiesclima.com)

## **Contents**

1	Models available .....	3
2	Application .....	4
3	Construction and Mode of Operation .....	4
4	Recommendation Side Selection / Standard Installation .....	4
5	Installation.....	5
5.1	Mechanical Mounting .....	5
5.2	Electrical Mounting .....	5
6	Plug Mounting .....	6
7	Maintenance .....	6
8	Connecting Diagram .....	7
9	Technical Data.....	8
10	Dimensional Drawing.....	9
11	Accessories .....	10
12	EC-Declaration of Conformity .....	11

## **Figures**

Figure 1:	Connecting diagram for models with cable .....	7
Figure 2:	Dimensional drawing with cable.....	9
Figure 3:	Dimensional drawing with plug.....	9

# 1 Models available

Order-No.	Meas. range	Electrical Output	Heating	Operating voltage	Connection
4.3129.60.140	0...360°	0...20 mA	20 W	15...30 V DC or 24 V AC	12 m cable LiYCY 6 x 0,25 mm <sup>2</sup>
4.3129.60.141	0...360°	4...20 mA	20 W	15...30 V DC or 24 V AC	12 m cable LiYCY 6 x 0,25 mm <sup>2</sup>
4.3129.60.161	0...360°	0...10 V	20 W	15...30 V DC or 24 V AC	12 m cable LiYCY 6 x 0,25 mm <sup>2</sup>
4.3129.60.167	0... 60°	0...2 V	20 W	8...30 V DC or 24 V AC	12 m cable LiYCY 6 x 0,25 mm <sup>2</sup>
4.3129.60.173	0...360°	0...5 V	20 W	8...30 V DC or 24 V AC	12 m cable LiYCY 6 x 0,25 mm <sup>2</sup>
4.3129.60.740	0...360°	0...20 mA	20 W	15... 30 V DC or 24 V AC	7 pole plug
4.3129.60.741	0...360°	4...20 mA	20 W	15...30 V DC or 24 V AC	7 pole plug
4.3129.60.761	0...360°	0...10 V	20 W	15...30 V DC or 24 V AC	7 pole plug
4.3129.60.767	0...360°	0...2 V	20 W	8...30 V DC or 24 V AC	7 pole plug
4.3129.60.773	0...360°	0...5 V	20 W	8...30 V DC or 24 V AC	7 pole plug
4.3129.80.140	0...360°	0...20 mA	60 W	15...30 V DC or 24 V AC	12 m cable LiYCY 6 x 0,25 mm <sup>2</sup>
4.3129.80.141	0...360°	4...20 mA	60 W	15...30 V DC or 24 V AC	12 m cable LiYCY 6 x 0,25 mm <sup>2</sup>
4.3129.80.161	0...360°	0...10 V	60 W	15...30 V DC or 24 V AC	12 m cable LiYCY 6 x 0,25 mm <sup>2</sup>
4.3129.80.167	0...360°	0...2 V	60 W	8...30 V DC or 24 V AC	12 m cable LiYCY 6 x 0,25 mm <sup>2</sup>
4.3129.80.173	0...360°	0...5 V	60 W	8...30 V DC or 24 V AC	12 m cable LiYCY 6 x 0,25 mm <sup>2</sup>
4.3129.80.740	0...360°	0...20 mA	60 W	15...30 V DC or 24 V AC	7 pole plug
4.3129.80.741	0...360°	4...20 mA	60 W	15...30 V DC or 24 V AC	7 pole plug
4.3129.80.761	0 ... 360°	0...10 V	60 W	15...30 V DC or 24 V AC	7 pole plug
4.3129.80.767	0...360°	0...2 V	60 W	8...30 V DC or 24 V AC	7 pole plug
4.3129.80.773	0...360°	0...5 V	60 W	8...30 V DC or 24 V AC	7 pole plug

## 2 Application

---

The wind direction transmitter is designed for the acquisition of the horizontal wind direction. The measuring values are output as electrical analogue signals. The measuring data available are ideally adapted to the supply in display instruments, recording instruments, datalogger, as well as process control systems.

For winter operation the instruments are equipped with an electronically regulated heating in order to guarantee a smooth running of the ball bearings, and to avoid ice-formation at the slot of the outer rotation parts. The electrical supply of wind transmitter heating is carried out, for ex., by our power supply unit, order-no. 9.3388.00.000.

Thanks to the 60-Watt-heating as well as to the optimized regulating characteristic, model no. 4.3129.80.xxx is especially suited for the extremely difficult application in high mountains or at other critical sites, where icing is to be expected.

## 3 Construction and Mode of Operation

---

The outer parts of the instrument are made of corrosion-resistant material ( aluminum, stainless steel, plastic ). The aluminum parts are additionally protected by means of an anodic coat. Labyrinth sealing protects sensitive parts inside the instrument against humidity.

The wind direction is detected by a low-inertia wind vane. The axis of the wind vane is running in ball bearings and carries a diametrically magnetized magnet at the inner end. The angle position of the axis is scanned contact-free by a magnetic angle sensor (GMR-Sensor = Giant Magnetoresistive Effect Sensor), which gives two sinus- and cosines-dependent voltages as output signals.

From this, a micro-controller calculates the wind direction, and the linear relationship between the angle and the analogue output.

## 4 Recommendation Side Selection / Standard Installation

---

In general wind measurement instruments should be able to detect the wind conditions of a large area. In order to obtain comparable values when determining the surface wind, measurements should be taken at a height of 10 meters over an even unobstructed area. An unobstructed area means that the distance between the wind transmitter and an obstacle should be at least 10 times the height of the obstacle ( s. VDI 3786 ). If it is not possible to fulfil this condition, then the wind transmitter should be set up a height where local obstacles do not influence the measured values to any significant extent (approx. 6-10 m above the obstacle).

The wind transmitter should be set up in the centre of flat roofs and not on the roof side in order to avoid bias in the direction (privileged directions).

## 5 Installation

---

**Attention:**

*Storing, mounting and operation under weather conditions is permissible only in vertical position, as otherwise water can get into the instrument.*

---

**Remark:**

*When using fastening adapters (angle, traverses, hangers etc.) please take a possible effect by turbulences into consideration.*

---

### 5.1 Mechanical Mounting

The mounting of the transmitter could be done for example at a traverse with a boring of PG 21 or on hangers with a boring of 29 mm  $\varnothing$ . (for ex. traverse *compact*, order-no. 4.3171.30.000). The connection cable or connecting plug is passed through the boring, and the wind direction transmitter is fixed with hexagonal nut (SW36) after the north alignment.

#### **North Alignment**

Rotate the case markings (north marking) on the shaft and on the protective cap until they are aligned. Then select an obvious point in a northerly direction in the surroundings ( a tree, a building etc.) with the aid of a compass. Take a bearing on this point over the wind vane and the counter weight of the wind direction transmitter, and when these coincide screw the wind transmitter into place. (the north marking must indicate to the geographic north).

### 5.2 Electrical Mounting

For electrical connection please refer to the connecting diagram.

## 6 Plug Mounting

Applies only to instruments with connection „plug“.

Coupling socket, Typ:Binder, Serial 423, EMC with cable clamp

Cable connection: without cable shield

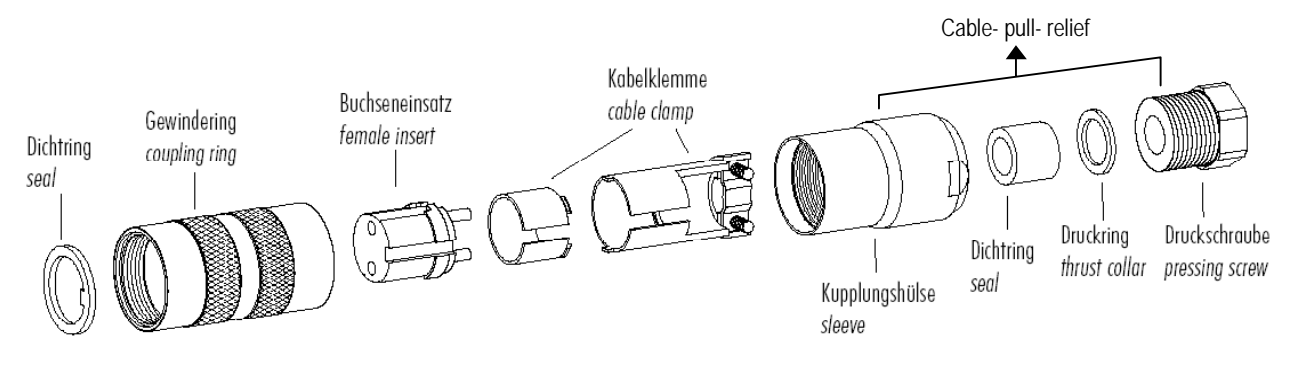

1. Stringing parts on cable acc. to plan given above.
2. Stripping cable sheath 20 mm
3. Cutting uncovered shield 20 mm
4. Stripping wire 5mm.
5. Soldering wire to the insert
6. Positioning shield in cable clamp.
7. Screwing-on cable clamp.
8. Assembling remaining parts acc. to upper plan.
9. Tightening pull-relief of cable by screw-wrench (SW16 und 17).

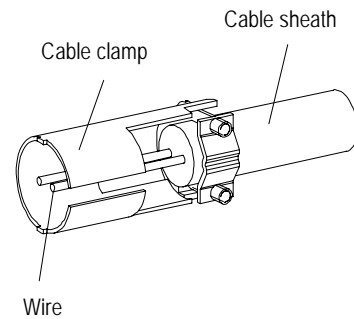

## 7 Maintenance

After proper mounting the instrument works maintenance free.

Heavy pollution can clog up the slit between the rotating and the stationary parts of the wind transmitter. This slit must be kept clean.

# 8 Connecting Diagram

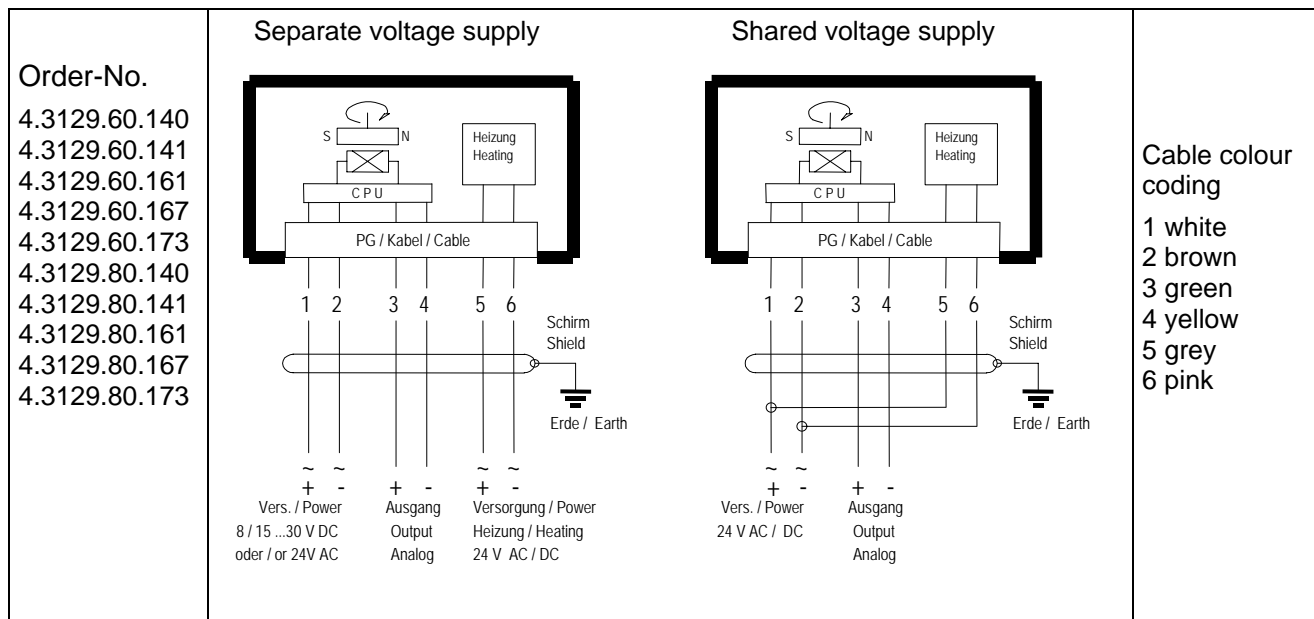

Figure 1: Connecting diagram for models with cable

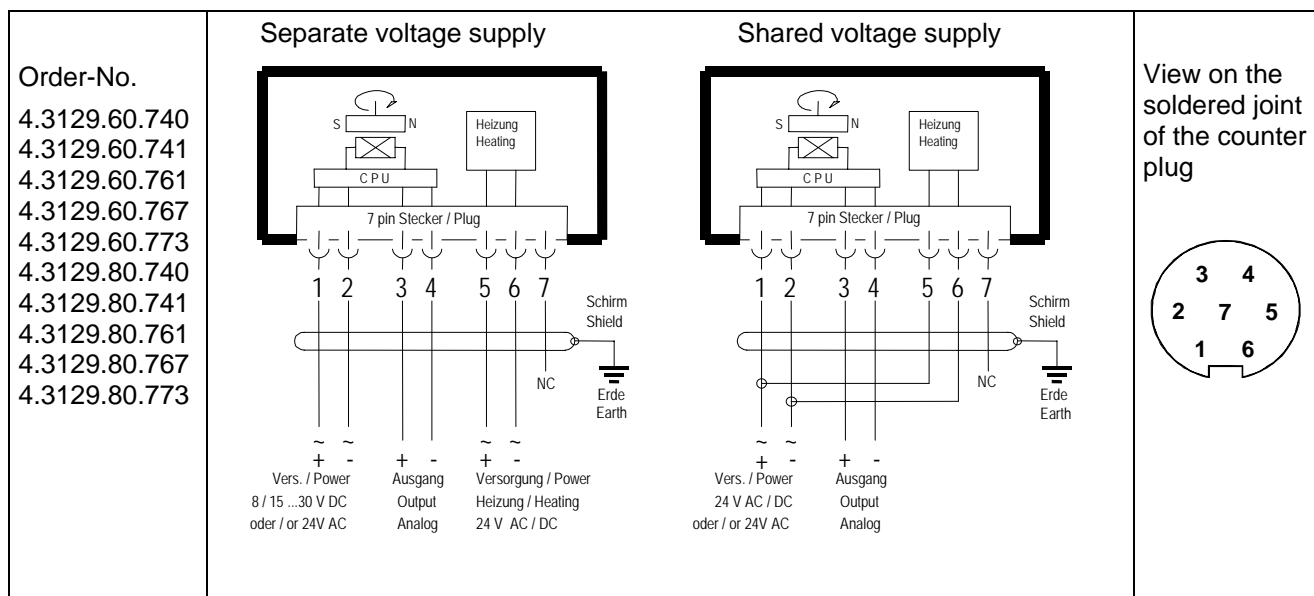

Figure 2: Connecting diagram for models with plug

## 9 Technical Data

Characteristic	Description / Value
Measuring range	0 – 360°
Resolution	ca. 0,4°
Accuracy	± 2°
Measuring principle	magnetic
Electrical output	See chapter 1 0 ... 20 mA; 4 ... 20mA @ 500Ω, U <sub>B</sub> ≥ 12V 0 ... 2V; 0 ... 5V @ 1000Ω 0 ... 10V @ 1000Ω, U <sub>B</sub> ≥ 12V
Operating voltage (Vcc)	8 / 15 ... 30 V DC
Current consumption	<10mA + I <sub>out</sub>
Operating voltage heating	
4.3129.60.xxx	24 V DC/AC, max. 20 W
4.3129.80.xxx	24 V DC/AC, max. 60 W
Ambient temperature	- 40 °C ... + 70 °C
Survival speed	maximally 80 m/s, 30 minutes
Connection	See model (chapter 1)
Dimensions	See dimensional drawing
Mounting	For ex. onto mast tube receptacle thread PG 21 or boring Ø 29 mm
Protection	IP 55, in position of application
Weight	
w/o cable	ca. 0,3 kg
with cable	ca. 0,3 kg + 0,075 kg / m cable
EMC	EN 61000-6-2 ( immunity) EN 61000-6-3 ( interfering transmission )
Material	
Housing	Aluminium (AlMgSi1)
Vane	Synthetic with carbon-fibre (PC-GF10)
Bottom	Synthetic (POM H2320)



# 10 Dimensional Drawing

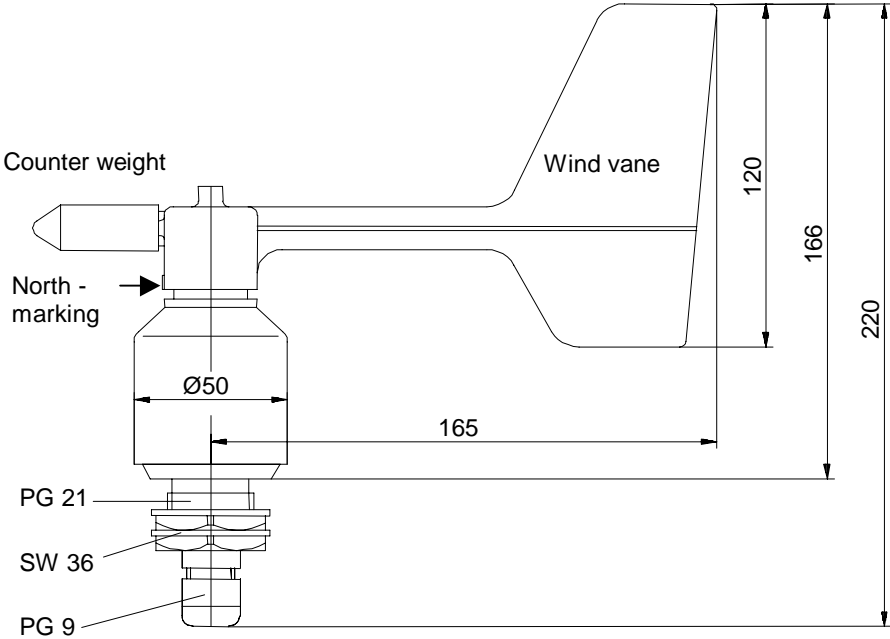

Figure 2: Dimensional drawing with cable

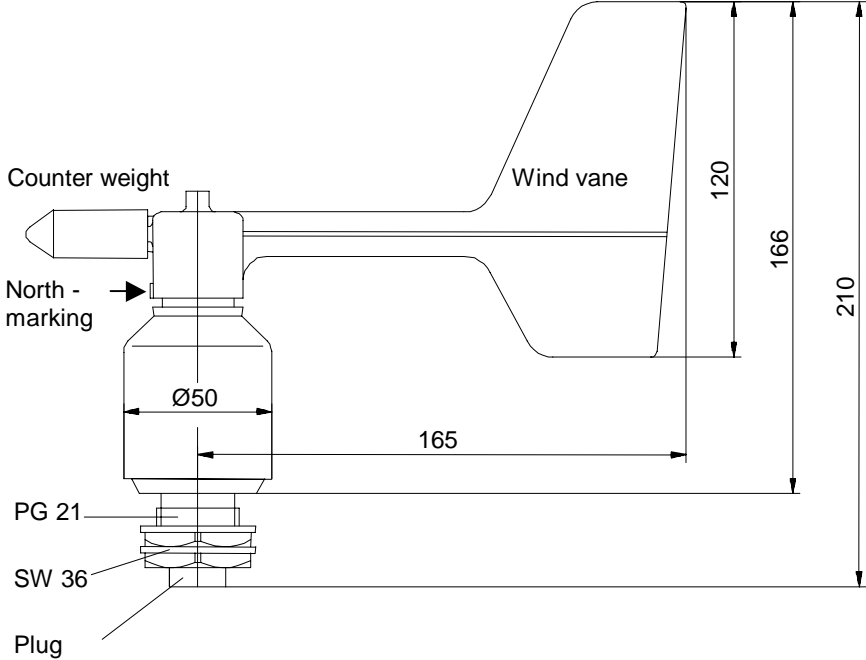

Figure 3: Dimensional drawing with plug

## 11 Accessories

---

The following accessories are available for the wind direction transmitter:

Traverse	4.3171.30.000	Clamping range: Ø 48 ... 102 mm
For mounting the wind speed transmitter and wind direction transmitter <i>compact</i> jointly onto a mast.	4.3171.31.000	Clamping range: Ø 116 ... 200 mm Sensor distance: 0,8 m Material: Aluminum

Traverse, short	4.3171.40.000	Clamping range: Ø 48 ... 102 mm
For mounting the wind direction transmitter <i>compact</i> onto a mast.	4.3171.41.000	Clamping range: Ø 116 ... 200 mm Length: 0,4 m Material: Aluminum

Lightning rod	506351	Length: 0,56 m
For mounting the a.m. traverses		Material: stainless steel

Please contact us for other accessories such as cables, power supply units, masts, as well as for additional mast- or system-constructions.

# 12 EC-Declaration of Conformity

Document-No.: 001223

Month: 06 Year: 09

Manufacturer: **ADOLF THIES GmbH & Co. KG**

Hauptstr. 76  
D-37083 Göttingen  
Tel.: (0551) 79001-0  
Fax: (0551) 79001-65  
email: Info@ThiesClima.com

Description of Product: **Wind Direction Transmitter – compact analog**

Article No.	<b>4.3129.00.140</b>	<b>4.3129.00.141</b>	<b>4.3129.00.161</b>	<b>4.3129.00.167</b>
<b>4.3129.00.173</b>	<b>4.3129.00.740</b>	<b>4.3129.00.741</b>	<b>4.3129.00.761</b>	<b>4.3129.00.767</b>
<b>4.3129.00.773</b>	<b>4.3129.00.940</b>	<b>4.3129.00.941</b>	<b>4.3129.02.141</b>	<b>4.3129.03.141</b>
<b>4.3129.04.767</b>	<b>4.3129.05.140</b>	<b>4.3129.05.141</b>	<b>4.3129.09.141</b>	<b>4.3129.39.141</b>
<b>4.3129.53.141</b>	<b>4.3129.60.140</b>	<b>4.3129.60.141</b>	<b>4.3129.60.161</b>	<b>4.3129.60.167</b>
<b>4.3129.60.173</b>	<b>4.3129.60.740</b>	<b>4.3129.60.741</b>	<b>4.3129.60.761</b>	<b>4.3129.60.767</b>
<b>4.3129.60.773</b>	<b>4.3129.80.140</b>	<b>4.3129.80.141</b>	<b>4.3129.80.161</b>	<b>4.3129.80.167</b>
<b>4.3129.80.173</b>	<b>4.3129.80.740</b>	<b>4.3129.80.741</b>	<b>4.3129.80.761</b>	<b>4.3129.80.767</b>
<b>4.3129.80.773</b>				

specified technical data in the document: **021071/01/08; 021189/06/05; 021453/06/05; 021487/06/09**

The indicated products correspond to the essential requirement of the following European Directives and Regulations:

2004/108/EC	DIRECTIVE 2004/108/EC OF THE EUROPEAN PARLIAMENT AND OF THE COUNCIL of 15 December 2004 on the approximation of the laws of the Member States relating to electromagnetic compatibility and repealing Directive 89/336/EEC
2006/95/EC	DIRECTIVE 2006/95/EC OF THE EUROPEAN PARLIAMENT AND OF THE COUNCIL of 12 December 2006 on the harmonisation of the laws of Member States relating to electrical equipment designed for use within certain voltage limits
552/2004/EC	Regulation (EC) No 552/2004 of the European Parliament and the Council of 10 March 2004 on the interoperability of the European Air Traffic Management network (the interoperability Regulation)

The indicated products comply with the regulations of the directives. This is proved by the compliance with the following standards:

Reference number	Specification
IEC 61000-6-2: 2005	Electromagnetic compatibility Immunity for industrial environment
IEC 61000-6-3: 2006	Electromagnetic compatibility Emission standard for residential, commercial and light industrial environments
IEC 61010-1: 2001	Safety requirements for electrical equipment for measurement, control and laboratory use. Part 1: General requirements

Place: Göttingen

Date: 15.06.2009

Legally binding signature:

issuer:

.....  
Wolfgang Behrens, General Manager

.....  
Joachim Beinhorn, Development Manager

This declaration certifies the compliance with the mentioned directives, however does not include any warranty of characteristics. Please pay attention to the security advises of the provided instructions for use.



## **ADOLF THIES GmbH & Co. KG**

Hauptstraße 76 37083 Göttingen Germany  
P.O. Box 3536 + 3541 37025 Göttingen  
Phone ++551 79001-0 Fax ++551 79001-65  
www.thiesclima.com info@thiesclima.com



- Alterations reserved-