

## Instruction for Use

021486/03/06

# **Baro Transmitter B-278-1T / -2T**

3.1158.x0.075



### **ADOLF THIES GmbH & Co. KG**

Hauptstraße 76

Box 3536 + 3541

Phone ++551 79001-0

[www.thiesclima.com](http://www.thiesclima.com)

37083 Göttingen Germany

37025 Göttingen

Fax ++551 79001-65

[info@thiesclima.com](mailto:info@thiesclima.com)

## **Contents**

1	Models available .....	3
2	Application/Construction/Mode of Operation .....	3
3	Mechanical Mounting .....	3
4	Electrical Mounting.....	4
4.1	Connection .....	4
5	Evaluation .....	5
6	Maintenance .....	5
7	Technical Data.....	5
8	Dimensional Drawing (inch / mm) .....	6

## 1 Models available

---

Description	Order-No.	Meas. Range	Output	Operating voltage
Baro transm. B-278-1T	3.1158.00.075	800 ... 1060 hPa	0 ... 5 V DC	9,5...28 V DC
Baro transm. B-278-2T	3.1158.10.075	600 ... 1060 hPa	0 ... 5 V DC	9,5...28 V DC

## 2 Application/Construction/Mode of Operation

---

The Baro Transmitter is designed for use in environmental applications that require excellent accuracy, fast dynamic response, and long-term stability and reliability.

To withstand the environmental extremes typically found in Automatic Weather Stations, the transmitter housing is made of environmental- and weather-proof materials. The electric connection is carried out via a 5-pole connector with screw-clamp.

The instrument operates in the temperature range from  $-40^{\circ}$  to  $+60^{\circ}\text{C}$ . The analogue output from 0-5V DC can be operated alternatively as 3- or 4-wire-circuit. The voltage supply is within a range from 9,5 – 28 V DC. The current consumption in the measurement mode is 3 mA nominal.

In the baro transmitter a capacitive ceramic-absolute-pressure sensor is used which features excellent thermal and mechanic stability.

## 3 Mechanical Mounting

---

The baro transmitter is used with air (up to 95 % r. h.), and non-conducting gases.

---

*Remark:*

*The use with liquids or corrosive gases may damage the instrument!*

---

The baro transmitter is equipped with a 1/8" hose connection, and is typically installed indoors or in weatherproof housing.

The baro transmitter should be installed vertically (connection clamp downwards) to prevent any ingress of condensed water.

## 4 Electrical Mounting

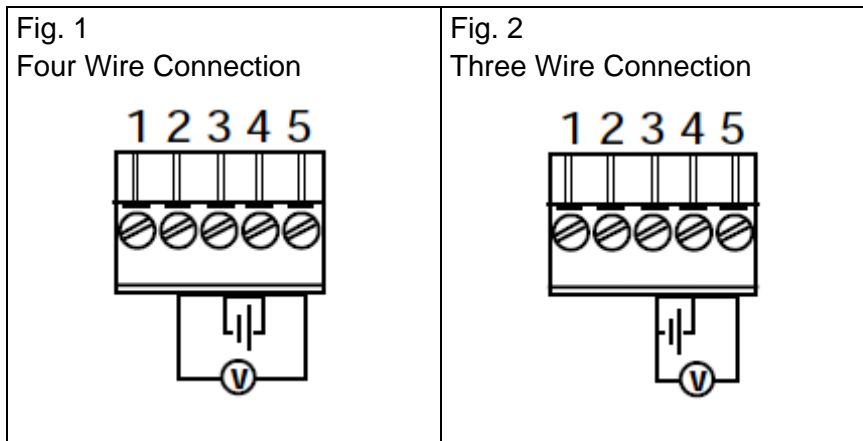

Pin assignment of the terminal strip:

Nr.	Terminal Strip	Function
1	EXT TRIG	No function
2	AGND*	Analogue signal ground
3	GND*	supply ground (-)
4	SUPPLY	supply (+)
5	VOUT	output

\* Both grounds (AGND and GND) are in the same electrical potential in the baro transmitter.

### 4.1 Connection

The ground connections AGND and GNG are in the same electrical potential. The connection is carried out in four- or three-wire-technology (see fig. 1 and 2). Four wire connection is recommended to avoid the voltage drop in the supply ground line, which can affect the accuracy of the pressure measurement. In normal operating mode no connection to the EXT.TRIG terminal is recommended. The barometers are protected against reverse operating voltage.

## 5 Evaluation

---

The barometric pressure (P) can be calculated from measured output voltage (U) using a equation:

$$\text{B 278-1T} \quad p = 800\text{hPa} + \frac{260\text{hPa}}{5\text{V}} \cdot U[\text{V}]$$

$$\text{B 278-2T} \quad p = 600\text{hPa} + \frac{460\text{hPa}}{5\text{V}} \cdot U[\text{V}]$$

## 6 Maintenance

---

Maintenance is not required. The baro transmitter is factory calibrated.

## 7 Technical Data

---

	<b>3.1158.00.075</b>	<b>3.1158.10.075</b>
Measuring element	capacitive	capacitive
Measuring range	800 ... 1060 hPa	600 ... 1060 hPa
Accuracy @ 20°C	± 0,3 hPa	± 0,5 hPa
Accuracy @ 0 ... 40°C	± 0,6 hPa	± 1,0 hPa
Accuracy @ -20 ... 50°C	± 1,0 hPa	± 1,5 hPa
Accuracy @ -40 ... 60°C	± 1,5 hPa	± 2,0 hPa
Linearity	± 0,25 hPa	± 0,4 hPa
Hysteresis	± 0,03 hPa	± 0,05 hPa
Long-term stability	± 0,1 hPa / year	± 0,1 hPa / year
<b>General</b>		
Electrical output	0 ... 5 V DC ( 0 V saturation voltage = 20 mV )	
Operating voltage	9,5 ... 28 V DC	
Current consumption	3 mA	
Electrical connection	Three- or four-wire technology	
Ambient temperature	-40...+60°C	
Connection	5 pole terminal strip	
Dimensions	61 x 91 x 25 mm	
Weight	0,14 kg	

## 8 Dimensional Drawing (inch / mm)

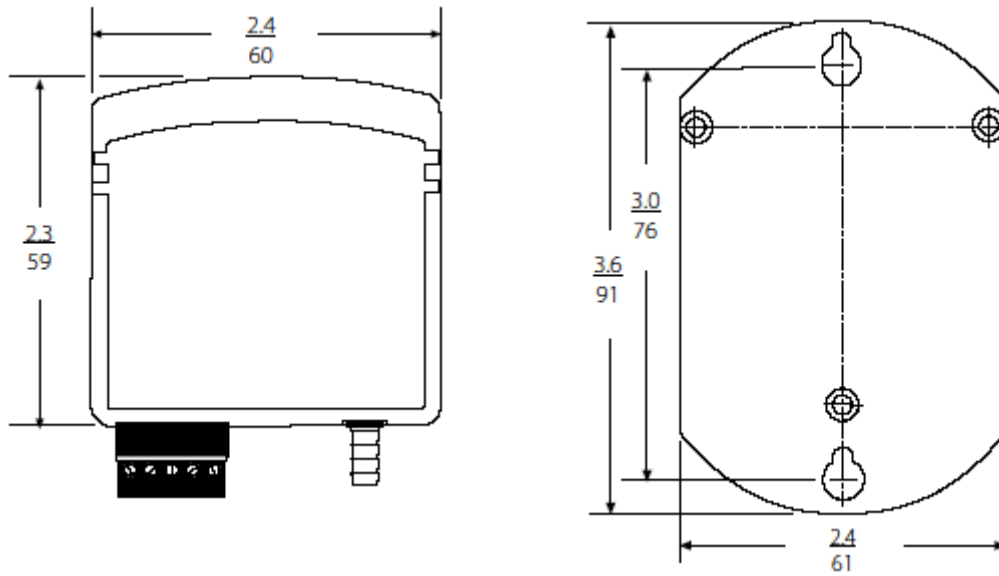

### ADOLF THIES GmbH & Co. KG

Hauptstraße 76 37083 Göttingen Germany  
P.O. Box 3536 + 3541 37025 Göttingen  
Phone ++551 79001-0 Fax ++551 79001-65  
www.thiesclima.com info@thiesclima.com



- Alterations reserved -