

Instruction for Use

020898/04/05

Hygrograph

1.0610.../ 1.0614.../ 1.0615...



ADOLF THIES GmbH & Co. KG

Hauptstraße 76

Box 3536 + 3541

Phone ++551 79001-0

www.thiesclima.com

37083 Göttingen Germany

37025 Göttingen

Fax ++551 79001-65

info@thiesclima.com

Contents

1	Models available	2
2	Application	3
3	Set-up and Mode of Operation.....	3
4	Preparation for Use.....	4
5	Maintenance	5
5.1	Changing the recording strip	5
5.2	Changing the Recording Pen	6
5.3	Regeneration of Humidity Measuring Instrument	6
6	Technical Data.....	7
7	Scale Drawing.....	7

Figures

Figure 1: Hygrograph.....	4
---------------------------	---

Tables

Table 1: Models available.....	2
Table 2: Recording strips	6

1 Models available

Order-No.	Recording Time	Clockwork	Lockable Housing
1.0610.xx.xxx	1 day / 7 days, switchable	Spring clockwork mechanism	
1.0614.xx.xxx	14 days / 31 days, switchable	Spring clockwork mechanism	
1.0615.xx.xxx	1 / 7 / 31 days, switchable	Quartz clockwork mechanism	
	Measuring element (humidity-measuring range)		
...10...	H (10...100 % rel.h. ; -35...+80 °C)		
...12...	K (0...100 % rel.h. ; 0...+80 °C)		
...000			no
...900			yes

Table 1: Models available

Attention:

■ *Hygrographs with Quartz clockwork mechanism are applicable only within the temperature range from -20 ...+60°C!*

2 Application

The hygrograph measures and records the relative humidity of the surrounding atmosphere. The recording drum is driven with utmost precision either by a manual spring clockwork mechanism or by a battery-operated quartz clockwork. Either H or K humidity measuring elements can be used depending on the general on-site operating conditions.

"H" measuring elements are suitable for taking measurements in normal to very moist air at temperatures below and above 0°C.

"K" measuring elements are designed for use in normal to dry air in the temperature range above 0°C and require no maintenance.

Typical applications include environmental monitoring in computer rooms, factories, warehouses, offices, laboratories, greenhouses, museums and galleries but they can also be used in meteorological measuring stations.

3 Set-up and Mode of Operation

The clockwork and the column with the humidity measuring element is mounted to a base plate. The instrument is protected by a tiltable transparent hood. The measuring element react promptly thanks to large ventilation openings in the direction of measurement.

Humidity is measured by a hair (H) or by a synthetic (K) measuring element. These measuring elements consist of several hairs or fibres whose lengths change when the humidity changes. This change in length is recorded by a felt pen onto a paper recording strip via a system of levers. The measurement accuracy indicated for the H measuring element applies to regenerated measuring elements in decreasing humidity.

4 Preparation for Use

Unscrew the knurled-head screw and open the hood. Remove the foam rubber from the hood (transport protection). Push the switch-off lever to the left to raise the recording pen from the recording strip.

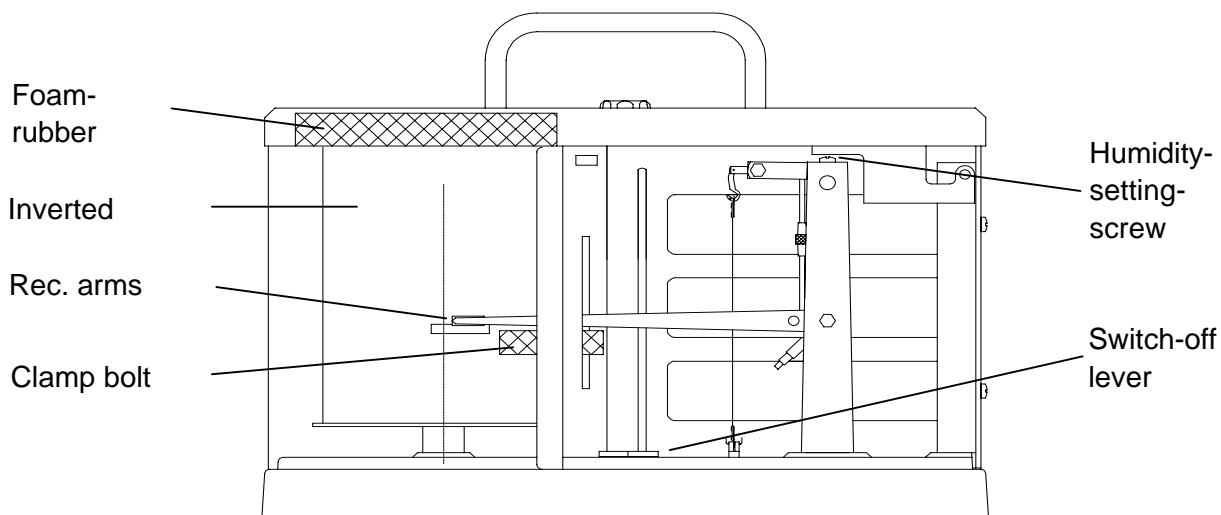
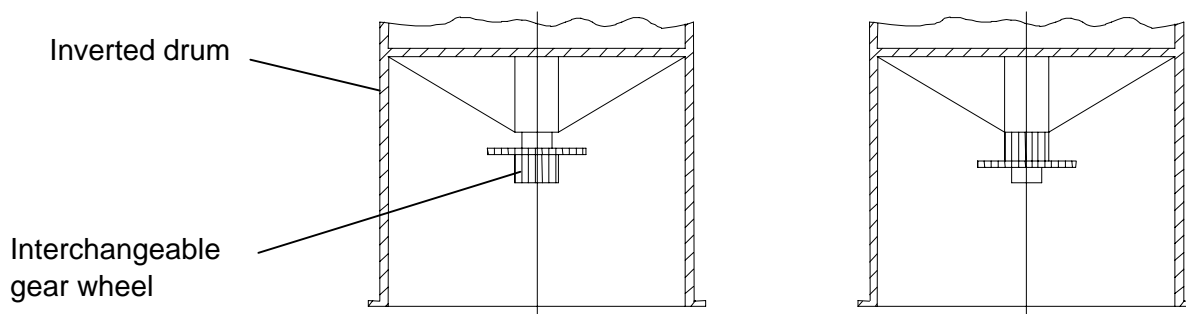

Figure 1: Hygrograph

Setting the desired recording time

For instruments with a spring clockwork mechanism, unscrew the winding key by turning it towards the right and remove the inverted drum from the drive mechanism. The desired recording time can be set by changing the interchangeable gear wheel on the drum.



Order-No.	Recording Time	Recording Time
1.0610.xx.xxx	1 day	7 days
1.0614.xx.xxx	14 days	31 days

Instrument with Quartz Clockwork

Remove the inverted drum from the drive mechanism and set the recording time with the red gear wheel by clicking it into place at the appropriate height. Make sure that the yellow gear wheel is properly engaged. Place the enclosed battery into the recess provided with the poles in the correct direction.

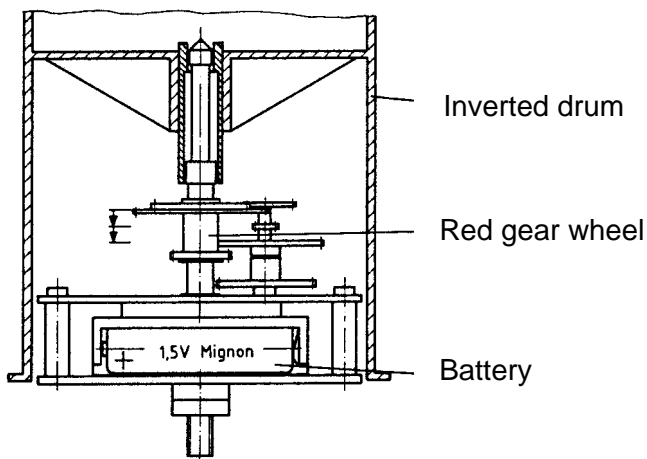

Position of the red gear wheel	
up	7 days
middle	31 days
down	1 day

Place the recording strip onto the inverted drum (see 5.1 Changing the recording strip) and insert this onto the drive mechanism until it locks into place!

Remove the recording arm from the clamp bolt (transport safety device). Remove the tip protector from the felt pen. For instruments with a spring clockwork mechanism, wind the clockwork with the key in the drum, turning it to the left. Rotate the drum counter-clockwise to the correct time. Close the hood and screw the knurled-head screws back into place. Press the switch-off lever to the right stop in order to move the recording pen onto the recording strip.

5 Maintenance

5.1 Changing the recording strip

This should be done regularly at the time where the recording strip starts; for example if you are using a 7 day recording period, then change the strip every Monday morning. After swinging the recording arm forwards, raise the chart holder and remove the recording strip. Place the new recording strip onto the drum and fix it into position by inserting the chart holder. Make sure that the new recording strip fits snugly and smoothly against the lower edge of the drum. Rewind the clockwork mechanism every time you change the recording strip. Swing the recording arm back to its original position and rotate the drum counter-clockwise to the correct time. The instrument is now ready for use.

Recording Strips(1 set = 100 sheets), Order-No. key

Measuring element "H"				Measuring element "K"			
1 day	7 days	14 days	31 days	1 day	7 days	14 days	31 days
205079	205077	205082	205083	205080	205078	-----	-----

Table 2: Recording strips

5.2 Changing the Recording Pen

Remove the inserted recording pen carefully from the recording arms after consumption. Remove the tip protection from the new pen. Make sure that you do not touch the recording tip when you place the new pen into position.

Spare Recording pen (minimum order of 6) Order-No. 500 847

5.3 Regeneration of Humidity Measuring Instrument

"H" measuring elements dry out when the relative humidity is less than 60%. This results in an increase in the zero point of approximately 5% or more rel. humidity. At ca. 60% rel. humidity, maximum inaccuracy is reached in 3 weeks. This time is shorter when the humidity value is even lower. Accuracy can be restored by regeneration. Simply place the instrument in saturated air for some hours. At the conclusion of the regeneration process, check whether the measuring element has returned to 95% rel. humidity. This value can be set on the humidity setting screw.

Measuring elements which are located out-of-doors or in huts regenerate automatically because the central European climate is such that, particularly at night – often a humidity of 95% occurs.

„K“ measuring elements do not degenerate and consequently do not have to be regenerated.

6 Technical Data

HUMIDITY

Measuring range	10 ... 100 % rel. humidity "H" 0 ... 100 % rel. humidity "K"
Graduation	5 % rel. humidity
Temp.- working range	-35 ... +70°C "H" 0 ... +80°C "K"
Measurement accuracy	± 2 % rel. humidity "H" + 1 Scale graduation @ 65% rel. h. and room temperature ± 3 % rel. humidity "K" + 1 Scale graduation @ 65% rel. h. and room temperature

CLOCKWORK

Spring clockwork mechanism

Recording time	1 day / 7 days or resp. 14 days / 31 days; (see models available)
Thrust	11,45 mm/h.; 40,01 mm/day or resp. 20 mm/day; 9 mm/day
Temperature range	-35 ... +80°C
Gear accuracy	± 60 s/Tag at 20°C acc. to DIN 8300

Quartz clockwork

Recording time	1 day / 7 days / 31 days
Thrust	11,45 mm/h.; 40,01 mm/day; 9 mm/day
Temperature range	-20 ... +60°C sim. DIN 8300 B
Gear accuracy	± 2 s/day
Battery capacity	> 1 year at 20°C (Mignon battery 1,5 V)

GENERALLY

Clockwork drum	Ø 93 x 93 sim. DIN 58658
Recording strip	sim. DIN 16232
Recording width	82 mm
Weight	2,2 kg

7 Scale Drawing

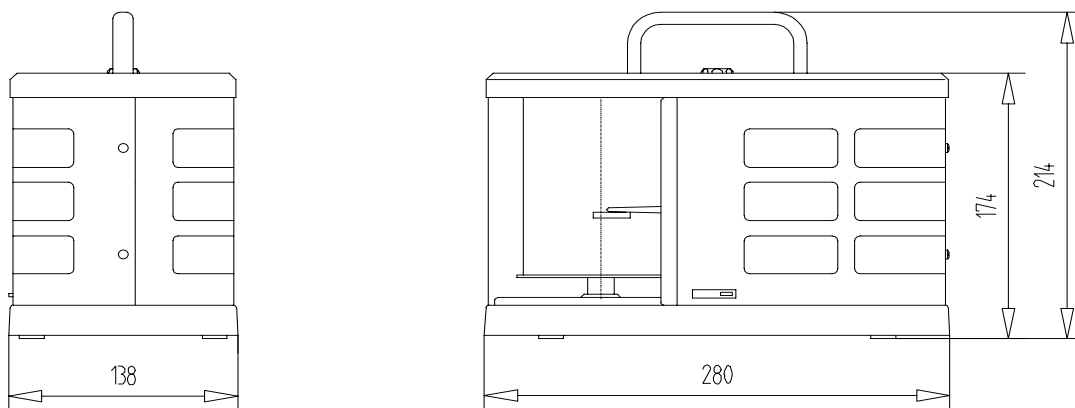



ADOLF THIES GmbH & Co. KG

Hauptstraße 76 37083 Göttingen Germany
P.O. Box 3536 + 3541 37025 Göttingen
Phone ++551 79001-0 Fax ++551 79001-65
www.thiesclima.com info@thiesclima.com



- Alterations reserved -