Precipitation Transmitter

5.4032.35.228



ADOLF THIES GmbH & Co. KG

Hauptstraße 76
Box 3536 + 3541
Phone ++551 79001-0
www.thiesclima.com

37083 Göttingen Germany
37025 Göttingen
Fax ++551 79001-65
info@thiesclima.com

Contents

1	Models	3
2	Application	3
3	Mode of Operation	3
4	Recommendation Site Selection / Standard Installation	4
5	Installation.....	4
5.1	Mechanical Mounting:	4
5.2	Electrical Mounting:.....	5
6	Maintenance	6
6.1	Cleansing Procedure.....	6
7	Check of the Tipping Bucket.....	7
8	Supply of Precipitation Transmitter to Output 1	8
9	Connecting Diagram	8
10	Technical Data.....	9
11	Dimension diagram.....	10
12	Accessories (<i>deliverable as options</i>).....	10

Figure

Figure 1: Instrument construction.....	5
--	---

1 Models

Order-No.	Heating	Heating Supply	Connection
5.4032.35.228	ja	24 V AC / DC; 48,5 W	1,5 m Kabel LiYCY 4 x 0,5 mm ²

2 Application

The instrument is designed to measure the height, quantity and the intensity of the precipitation striking the surface of the earth. The measuring principle is basing on the description „Guide to Meteorological Instruments No 8“ of the WMO (World Meteorological Organization).

3 Mode of Operation

The rain, collected by the collecting surface of 200 cm², is conducted through a inflow-sieve into a tipping-bucket. After having collected the rain amount of 4 cm³ = 0,2 mm of precipitation the bucket tips over, and the other tipping-bucket halve is ready for collecting the rain.

This tipping procedure is detected by Reed-switches, and induces an output pulse in combination with connected electronics. The procedures recur with continuous precipitation.

$$4 \text{ cm}^2 \text{ tipping-bucket volume} = 1 \text{ tipping-bucket puls} = 0,2 \text{ mm precipitation}$$

As the number of tipping procedures is not linear to the precipitation intensity, an intensity-dependent linearization is carried out in the connected electronics. The linearization procedure is basing on a precipitation-intensity-dependent pulse-number-correction for the precipitation intensity range of approx. 0,5 ... 15 mm/min

- The instrument 5.4032.35.228 is equipped with an electronically regulated heating for winter operation.
- All parts are corrosion-resistant. The cover is made of stainless steel (V2A).

For information

A precipitation height of 1 mm corresponds to a water volume of 1 litre on 1 m² ground area.

4 Recommendation Site Selection / Standard Installation

Depending on the wind velocity, a certain amount of the precipitation particles are blown away over the deposit area. Therefore, an installation in a completely open area as well as at the direct lee-side of an object is to be avoided. Gardens e.g., where hedgerows or similar objects offer protection against the wind, are more suitable.

The World Meteorological Organization recommends that precipitation gauges be installed at a distance which is at least four times as high as the next higher object. If this is not possible, it is to be observed that an elevation angle of $\leq 45^\circ$ towards the surrounding plants, buildings etc. is adhered to.

The precipitation gauge is to be installed in such a way that the collection area is horizontal and is situated 1 m above ground. If snowfall is to be expected regularly within the area of the measuring instrument this distance should be increased respectively.



Attention

Precipitation gauges are to be installed in a way that ensures a vibrationless operation.

5 Installation



Please Note:

***The electrical connection is to be carried out by experts only.
Please open the instrument only with dry ambient conditions.
Do not damage the exposed electronics!***

5.1 Mechanical Mounting:

Installation is carried out as follows:

(see also **Fig. 1: instrument construction**)

- Unpack the instrument.
- Remove the tipping bucket **(9)** from the collecting funnel of the casing **(7)** (in a separate small carton) and unpack it, as well.
- Put the precipitation transmitter onto an applicative stand and fix it by means of the screws **(12)**.
- Unscrew 2 screws **(1)** at the casing **(7)** and remove the casing carefully.
- Check, if the level on the base plate **(11)** indicates vertical mounting, possibly correct it by means of the screws **(12)** in the stand.
- For inserting the tipping bucket **(9)** the collector **(4)** must be moved upwards by unscrewing the knurled screws.

- Then insert the tipping bucket carefully into the bearing seat.
- Important:** The magnet of the tipping-bucket must indicate towards the pc-board.
- Afterwards, check the tipping bucket if the tips go accurately.
 - Then put the collector back into the lower position and fix it there.
 - Replace carefully the case over the instrument from above and tighten the 2 housing screws.

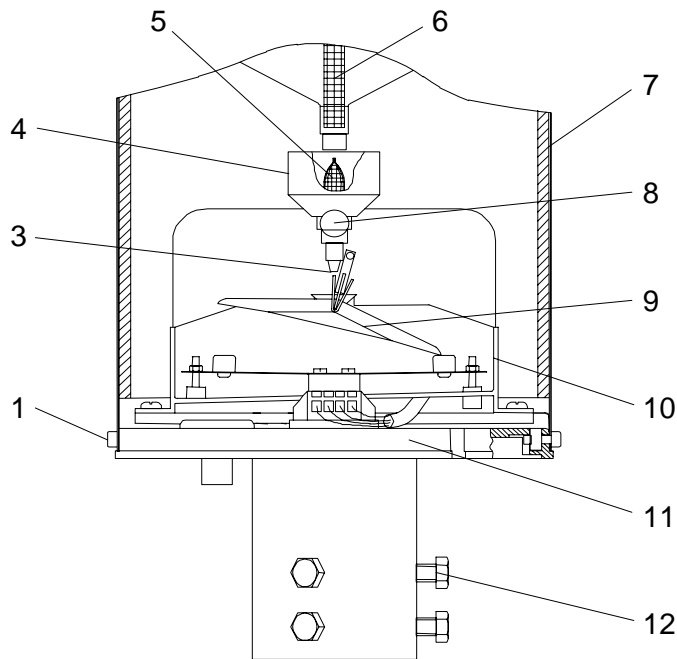

Figure 1: Instrument construction



Attention

Do not touch the inner surfaces of the tipping bucket.

Remark

Please remove the inflow sieve (6) in the collecting funnel during the winter period when it is snowing!

5.2 Electrical Mounting:

- A 4 pole cable is connected to a terminal strip integrated in the precipitation transmitter. The further electrical connection is to be carried out acc. to the connecting diagram (see chap.9).

6 Maintenance



Please Note:

***The electrical connection is to be carried out by experts only.
Please open the instrument only with dry ambient conditions.
Do not damage the exposed electronics!***

The instrument is designed in such a way that all of the parts requiring maintenance are easily accessible once the case has been removed.

The most important factors for precise measurements are a free and undisturbed inflow, and clean, grease-free inner surfaces of the tipping bucket.

The tipping bucket is made of zinc-plate, the surface of which is specifically oxidised, in order to achieve a hydrophile surface. It guarantees an accurate draining behaviour of the measuring liquid, and must not be removed mechanically.

The maintenance interval should depend on the degree of pollution of the instrument. It is advisable to make a visual inspection at short intervals as particles falling from above, such as foliage, bird dropping etc. can affect the measurement.

6.1 Cleansing Procedure

What you need for cleansing:

- ✓ a clean cloth
- ✓ a small bottle brush
- ✓ a soft brush
- ✓ possibly gentle soap

Cleansing is carried out as follows: (s.a. Fig. 1: Instrument construction):

- Switch off supply voltage of heating.
- Remove **the inflow sieve (6)** from the **case (7)** (collecting funnel) from above and clean it.
- Unscrew the **2 screws (1)** at the cover, remove and clean it.
- Remove **sieve (5)** from the **collector (4)** and clean it.
- The **collector (4)** with the **nozzle (3)** can be removed after unscrewing the **knurled screw (8)**. Clean the nozzle boring by means of small bottle brush.
- Remove the **tipping bucket (9)** carefully from the bearing seat.
- Clean the inner surfaces with clear water, if heavily soiled (grease) also with gentle soap water. For this, please use a soft brush.
- If indicated, clean also the **run-off pan (10)**.
- After cleansing, please re-insert the parts in reversed order.



Attention

- ***Do not use any benzene, alcohol, or other cleansing agents.***
- ***Never treat the inner surfaces of the tipping bucket with emery paper or something similar.***
- ***Do not touch the inner surfaces with hands.***

7 Check of the Tipping Bucket

For checking the measuring instrument it is advisable to pour a certain amount of precipitation slowly and steadily into the collecting funnel. That means, that for example a quantity of 400 cm² induces a pulse number of 100.

The quantity of 400 cm² should be filled in constantly over a period of approx. 10 minutes.

Remark:

Every precipitation transmitter is checked, adjusted and calibrated at the manufacturers. If, in the course of time, the adjustment of the tipping bucket has changed as a result of external influences, we suggest a check and calibration in our factory.

8 Supply of Precipitation Transmitter to Output 1

The precipitation transmitter is supplied via the signal line (two-wire-circuit).
Therefore, Ra may be a maximum of 10kΩ in the interface at a voltage of Vcc = 5v.

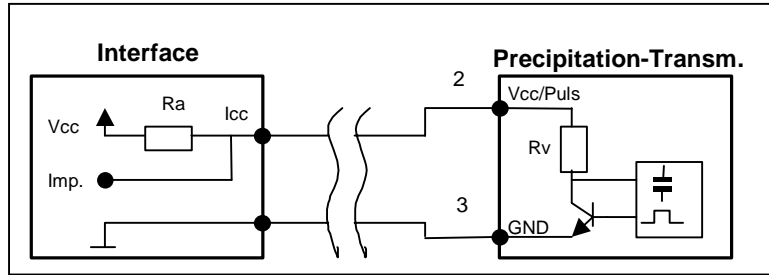

9 Connecting Diagram

5.4032.35.228

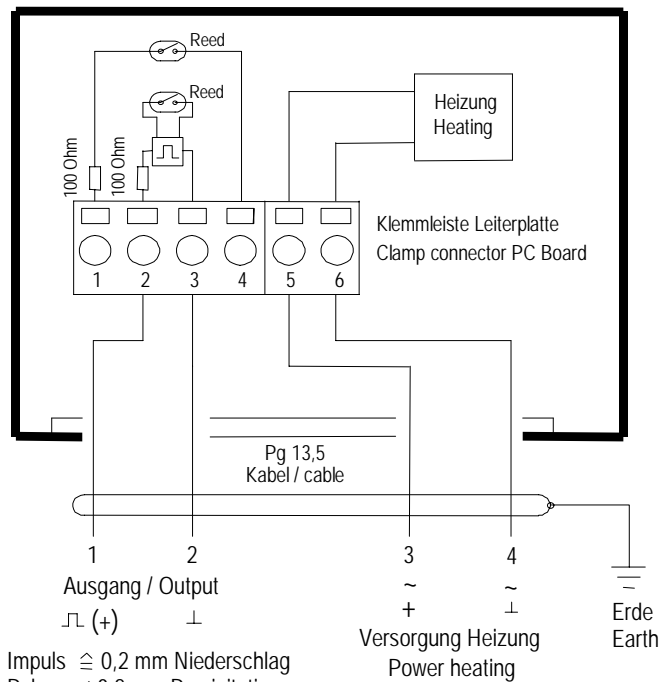

1 Impuls \cong 0,2 mm Niederschlag
 1 Pulse \cong 0,2 mm Precipitation
 V_{cc} = 5...24 V DC
 I_{Impuls} = 80 mA / max
 t_{Impuls} = 125 ms

10 Technical Data

Description	MIN	TYP	Max	Units
General				
Collector surface		200		cm ²
Volume of tipping bucket		4		cm ³
Measuring range	0		15	mm/min
Measuring range		0.2		mm NS
Accuracy within the range of 0.. 15mm/min			± 3 *	%
Ambient temperature (without heating)	0		60	°C
Ambient temperature (with heating)	- 15		60	°C
Mounting onto mast tube (1 ½")			50	Ømm
Weight			3.3	kg
Cable Length (LiYCY 4x0.5 mm ²),fixedcmounted		1.5		m
Output signal:				
Pulse length		125		ms
Pulse frequency	0		2	Hz
Operating voltage	5		24	V DC
Standing current (no precipitation)		35	50	µA
Pulse current			80	mA
Ra Max (Ra in the Interface (Vcc=5V)			10	kΩ
Rv (pre-resistance in the precip.transmitter)		100		Ω
Heating:				
Heating voltage		24		V(AC/DC)
Heating power		48.5		W
Heating – switch-on temperature		5		°C
Heating – hysteresis		2		°C

- * = The accuracy were determined under laboratory conditions
- Medium: Water
- Test - Volumen: 400 ml (= 20mm Precipitation = 100 Tipping bucket pulses)

11 Dimension diagram

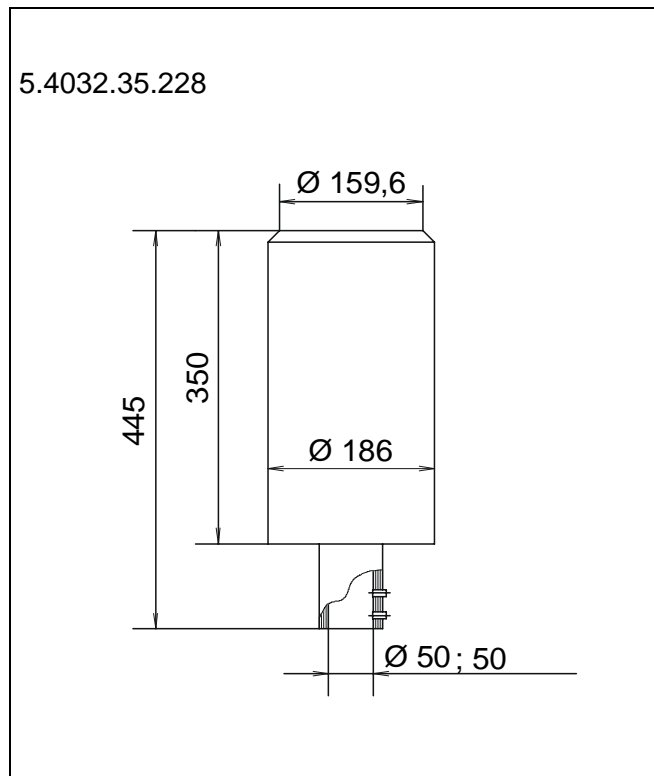

12 Accessories *(deliverable as options)*

Stand	9.4031.35.065	Serves for mounting the precipitation transmitter. The distance from the ground to the collecting surface is about 1,0 meter. Stands are available also for other distances.
Bird protection device	5.4010.00.010	Avoids birds sitting on the precipitation transmitter.
Power Supply Unit	9.3388.00.000	Serves for current supply of precipitation transmitter heating. Primary: 230 V / 50 Hz Secondary : 26V / 3,46 A

Other accessories on request.

	ADOLF THIES GmbH & Co. KG			
	Hauptstraße 76 37083 Göttingen Germany P.O. Box 3536 + 3541 37025 Göttingen Phone ++551 79001-0 Fax ++551 79001-65 www.thiesclima.com info@thiesclima.com			

- Alterations reserved -