

Instruction for Use

021517/12/06

Wind Direction Transmitter „First Class“

Device with digital output RS 485

4.3150.x0.400



ADOLF THIES GmbH & Co. KG

Hauptstraße 76

Box 3536 + 3541

Phone ++551 79001-0

www.thiesclima.com

37083 Göttingen Germany

37025 Göttingen

Fax ++551 79001-65

info@thiesclima.com

Contents

1	Models available	2
2	Application	3
3	Mode of Operation	3
4	Recommendation Site Selection / Standard Installation	4
5	Installation.....	4
5.1	Mounting of the Wind Vane	4
5.2	Electrical Mounting	5
5.3	Mechanical Mounting	5
5.4	North Alignment.....	6
5.5	Plug mounting	6
6	Connecting Diagram	7
7	Serial Interface (RS485)	8
8	Placing into operation	8
9	Command Interpreter.....	9
10	List of Commands.....	10
11	Maintenance	13
12	Technical Data.....	14
13	Dimensional drawing	15
14	Accessories	16

Figures

Figure 1: Mounting of the wind vane	5
---	---

1 Models available

Order- No.	Measuring range	Electrical output	Supply	Heating
4.3150.00.400	0...360°	RS 485	3.3...42V DC	ja (24 V AC / DC)
4.3150.10.400	0...360°	RS 485	3.3...42V DC	nein

2 Application

The wind direction transmitter serves for the detection of the horizontal wind direction in the field of meteorology and the technology of environmental protection.

Special characteristics:

- High level of measuring accuracy and resolution
- High damping ratio at a small delay distance
- Low starting threshold
- Low current consumption (3,3V@1,0mA)
- Easy removal, and mounting when changing the ball bearing

For winter time use the wind direction transmitter (see chapter 1 models available) is optionally equipped with an electronically regulated heating, which guarantees the smooth-running of the ball bearing, and prevents ice forming in the space between the external rotation parts. Electrical supply of the wind transmitter heating is provided for ex.. by our power supply unit order-no. 9.3388.00.000.

Remark:

When using fastening adapters (angle, traverses, etc.) please take a possible effect on the measurements by turbulences into consideration.

3 Mode of Operation

The dynamic characteristics of the wind vane is achieved by the aluminum light-weight construction. The co-action of wind vane and balance weight results in a high damping ratio with small delay distance as excellent characteristic of the complete vane.

The axis of the wind vane is running in ball bearings and carries a diametrically magnetized magnet at the inner end. The angle position of the axis is scanned contact-free by a magnetic angle sensor through the position of the magnet field. As the sensor is operated in magnetic saturation, effects by external magnetic fields can almost be eliminated. The connected electronics calculates the angle position of the axis and provides the respective serial output signal.

An AC- or DC-voltage of 24 V is intended for the separate supply of the optional heating. In all probability, the heating guarantees a trouble-free function of the Wind Direction Transmitter First Class even under extreme meteorological icing-conditions..

The outer parts of the instrument are made of corrosion-resistant anodized aluminum, and stainless steel. Highly effective labyrinth gaskets and O-rings protect the sensitive parts inside the instrument against humidity and dust.

4 Recommendation Site Selection / Standard Installation

In general wind measurement instruments should be able to detect the wind conditions of a large area. In order to obtain comparable values when determining the surface wind, measurements should be taken at a height of 10 meters over an even area with no obstacles. An area with no obstacles means that the distance between the wind direction transmitter and an obstacle should be at least 10 times the height of the obstacle (s. VDI 3786 Part 2). If it is not possible to fulfill this condition then the wind direction transmitter should be set up a height where local obstacles do not influence the measured values to any significant extent (approx. 6-10 m above the obstacle). The wind direction transmitter should be set up in the center of flat roofs and not on the edge in order to avoid any preferential directions.

5 Installation

5.1 Mounting of the Wind Vane

Before the wind direction transmitter can be installed at a selected site, the wind vane and the balance weight must be mounted at the adaptors of the wind direction transmitter. The individual process steps are explained in the following list, and by the drawing (figure 1). Necessary tool: Philips screw driver.

- **Wind vane:**
 - Remove the screw M3 from the thin adaptor.
 - Put the wind vane onto the thin adaptor. (The longer part of the wind vane deflector must indicate upward).
 - Put the screw M 3 through the hole of the wind vane from below into the adaptor, and screw tight.
- **Balance weight:**
 - Remove the screw M3 from the thicker adaptor.
 - Put the balance weight onto the thicker adaptor.
 - Put the screw M 3 through the hole of the balance weight from below into the adaptor, and screw tight.

Remark:

As the screws are covered with locking varnish they are rough-running with the fastening.

The screw head must be immersed completely in the counter-bore of balance weight and wind vane!

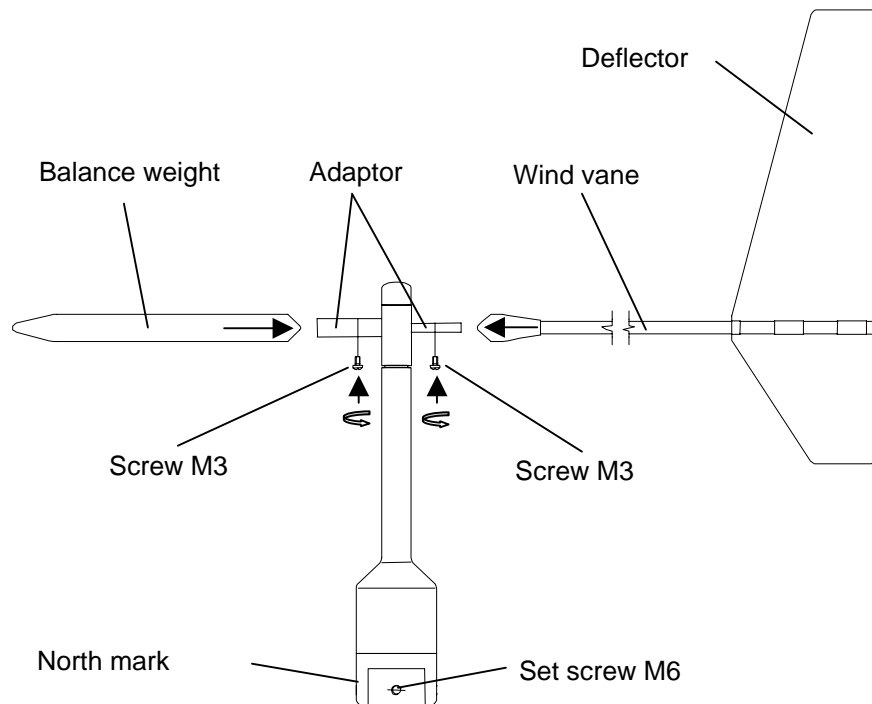

Figure 1: Mounting of the wind vane

5.2 Electrical Mounting

Solder a shielded cable with diameter 7-8 mm and a core cross-section of 0,5...0,75 mm² to the enclosed coupling socket.

- The number of necessary wires is given in the connection diagram (chapter 8).

Cable recommendation	
Type/ No. of cores /Diameter	Cable diameter
LIYCY 4 x 0,75 mm ²	ca. 7 mm
LIYCY 5 x 0,50 mm ²	ca. 7 mm
LIYCY 6 x 0,75 mm ²	ca. 7,7 mm
LIYCY 7 x 0,50 mm ²	ca. 7,5 mm
LIYCY 8 x 0,50 mm ²	ca. 8 mm

5.3 Mechanical Mounting

Mount the transmitter onto a pipe socket of R 1" (Ø 33,5 mm) and a length of 25 mm. The pipe socket must have an internal diameter of at least 25 mm as the wind direction transmitter must be connected electrically with a plug from below. After electrical connection the wind direction transmitter is put onto the pipe socket, and is fixed by means of 2 threaded pins (female hexagon 3 mm) at the base of the transmitter.

Attention:

Storing, mounting and operation under weather conditions is permissible only in vertical position, as otherwise water can get into the instrument.

5.4 North Alignment

Remark:

When the wind direction transmitter is in operation, the north marking (line mark) at the base of the transmitter must indicate to the geographical north.

5.5 Plug mounting

Coupling socket 507550 (Binder, Serial 423), EMC with cable clamp

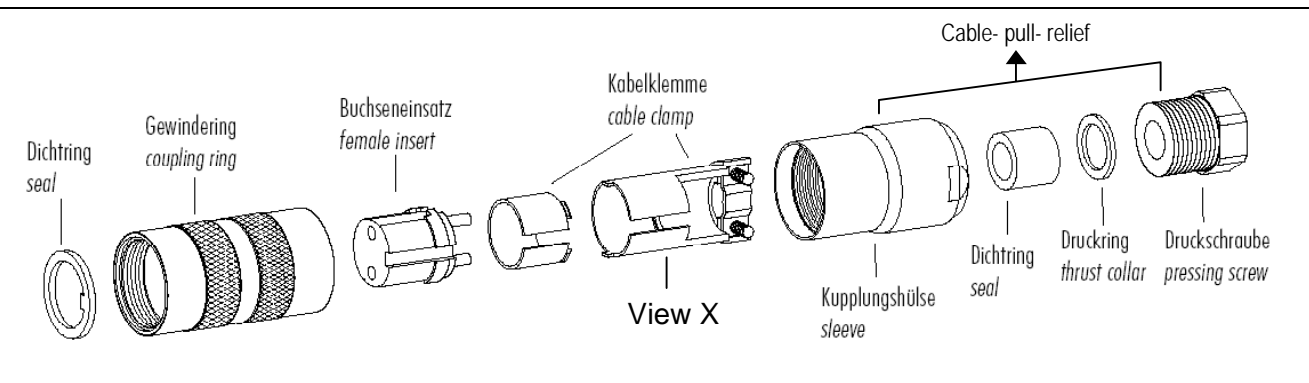

1. Stringing parts on cable acc. to plan given above.
 2. Stripping cable sheath 20 mm
Cutting uncovered shield 15 mm
Stripping wire 5mm.
- Cable mounting 1*
Putting shrink hose or insulating tape between wire and shield.
- Cable mounting 2*
If cable diameter permits, put the shield backward on the cable sheath.
3. Soldering wire to the insert, positioning shield in cable clamp.
 4. Screwing-on cable clamp.
 5. Assembling remaining parts acc. to upper plan.
 6. Tightening pull-relief of cable by screw-wrench (SW16 und 17).

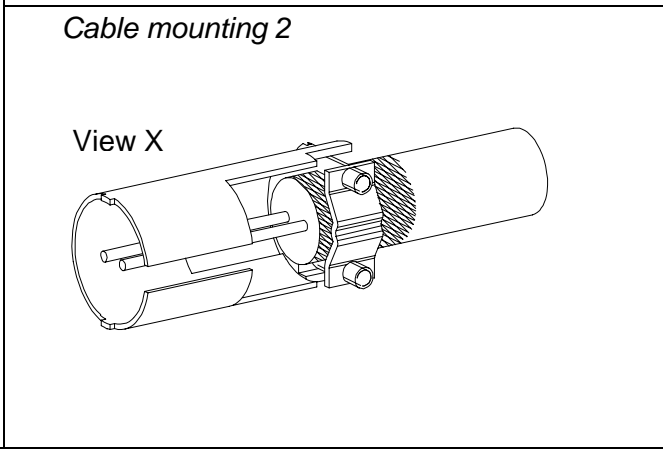
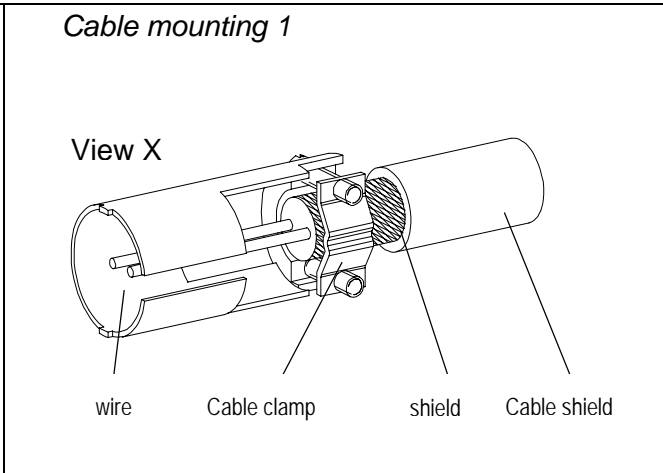

6 Connecting Diagram

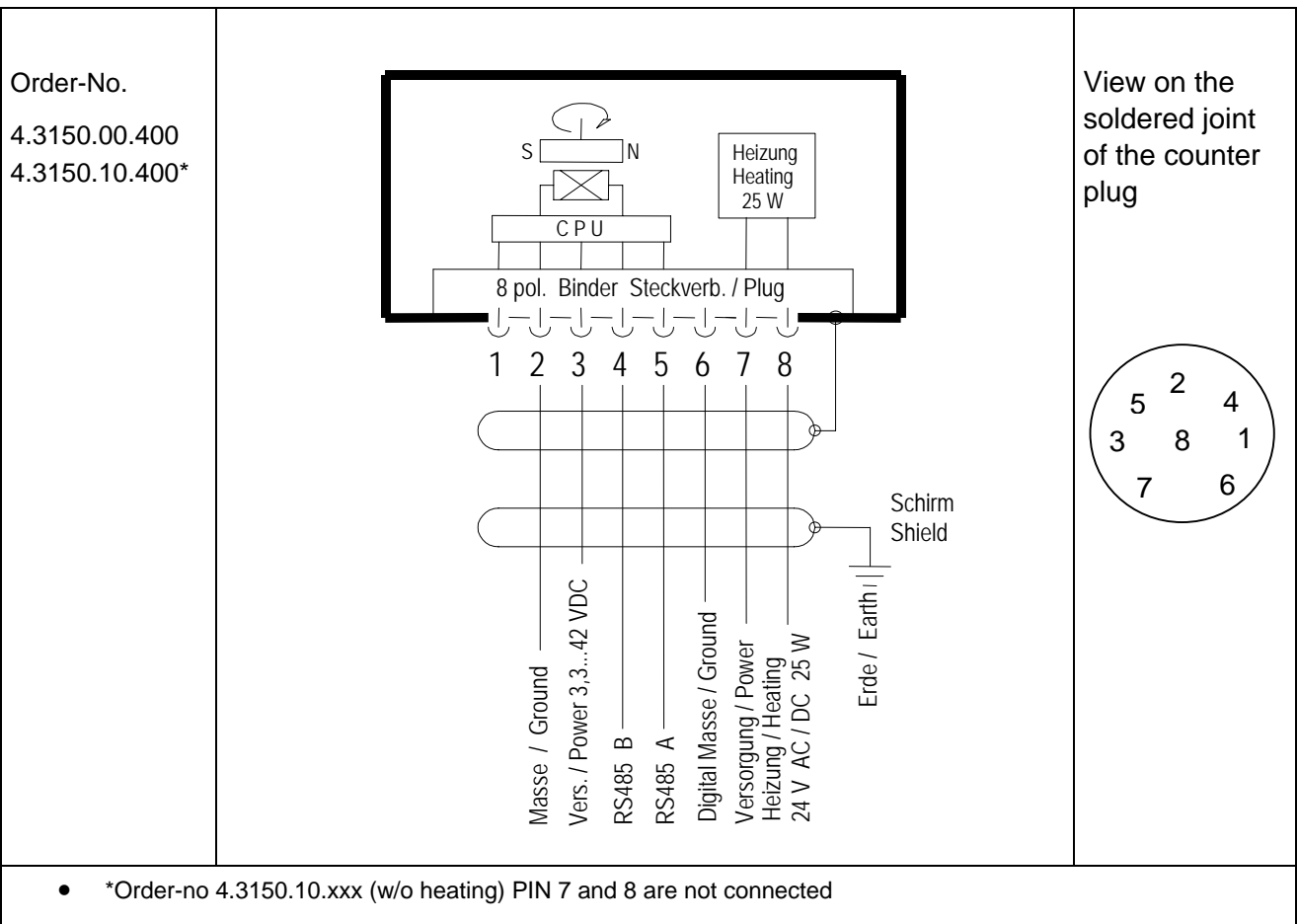

Contact	Name	Function
1	-----	Do not apply
2	GND	Supply ground
3	+Vcc	Supply 3.3 V ... 42 V DC
4	Serial B	RS 485 (B), serial- synchron Clock
5	Serial A	RS 485 (A), serial- synchron Clock
6	DGND	Digital ground
7	HZG	Heating supply:
8		Voltage: 24 V AC/DC Power: 25 W

*Order-no 4.3150.10.xxx (w/o heating) PIN 7 and 8 are not connected

7 Serial Interface (RS485)

The wind transmitter has an RS485 interface, which is operated in half-duplex mode. For a respective termination (terminating resistance) of the connecting cable must be provided externally (no termination in the wind transmitter).

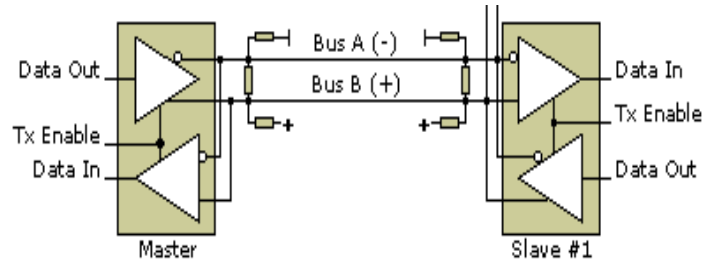

Principle circuit
diagram

8 Placing into operation

Connect the wind transmitter to a power supply unit, and an RS484 interface, as described in the connecting diagram. With applying the supply voltage the output of the wind direction starts automatically, after a delay of 5 seconds, with the following setting:

Setting of interface :

Baud rate	9600 baud
Data bits	8 bit
Parity bit	no
Stop bit	1

Data telegram:

xxx.xx<CR>	z.B. 275.54<CR>	<CR> = 0x0D Hex = Carriage-return
Data output	automatic	
Output interval	100ms	

9 Command Interpreter

For communication purpose the wind transmitter has a command interpreter. By means of this interpreter the behavior of the instrument can be changed. Thus, for example, the baud rate the instrument ID, and the starting behavior can be adapted to the own requirements. On principle, the command has the following construction:

AABB<CR> or AABBCCCCC<CR>

with:

AA: Wind transmitter – ID. Is always two-digit and in the range 00. 98

ID-works setting: 00

BB: the command, see list of commands

CCCCC: A five-digit value for setting a new parameter value.

<CR>: Means here carriage-return (enter-button). This sign terminates the entering of commands.

A check of the command syntax is carried out in the wind transmitter. The correct reception of a command is acknowledged with „echo telegram“ for ex.:

00BR00005<CR> transmitting command

!00BR00005<CR> echo telegram

If a command is transmitted to the instrument without parameter value, it serves for querying the value currently set. For example, by means of the command

00BR<CR>

the current baud rate is queried. The reply telegram, for ex., appears as follows:

!00BR00005<CR> **00005** = 9600baud (see table of baud rates)

In order to avoid an unmeant parameter adjustment some commands (see list of commands) are secured by a so-called “key”. This “key” must be transmitted before the actual modification command.

Example: modification of baud rate

00KY00001<CR> Key-secured command released

00BR00006<CR> baud rate set to 19200

Attention:

The key-secured commands are released until the supply voltage is activated, or the command 00KY00000<CR> is transmitted.

Automatic Baud Rate Setting:

If the baud rate of a wind transmitter is unknown, it can be set or detected by the following method. For this, it is necessary to set a possible baud rate (see table of baud rates).

- Constant transmission of the sign <CR> (for ex. approx. 4sec constant confirmation of enter button)
- Constant transmission of the command <id>BR<CR> until the wind transmitter replies with the telegram !xxBR0000x . The parameter contains then the parameter identification (see table of baud rates) for the preset baud rate.

10 List of Commands

For the wind transmitter the following commands are available

	Command	Description	Key
Command KY	<id>KY<param>	KEY-Number (Access authorization)	No
Command TR	<id>TR<param>	Telegram on request	No
Command BR	<id>BR<param>	Setting the baud rate	Yes
Command TT	<id>TT<param>	Automatic Telegram output (ATG) ON/OFF	Yes
Command OR	<id>OR<param>	Setting output interval for ATG	Yes
Command ID	<id>ID<param>	Setting wind transmitter ID	Yes

Command KY

<id>KY<param> Release (cancel) KEY secured command

<id>KY Query of the current KEY- parameter

Command echo !xxKYxxxxx

Description: The next command, for ex. command BR for changing the baud rate, is released by transmitting the KEY- command through the parameter 00001

The KEY command through Parameter 00000, or switching-on the supply voltage resets the release.

Parameter description:

Parameter	Description
00000	Access authorization canceled
00001	Access authorization released

Command TR

<id>TR<param> Telegram on request
<id>TR Query is not relevant (!xxTR00000)
Command echo no Echo

Description: By transmitting the TR-command through parameter 00001 a measurement is initiated in the wind transmitter, und afterwards the reply telegram (xxx.xx<CR>) is transmitted with the current wind direction for ex. 187.21 .

Parameter description:

Parameter	Description
00001	Current measurement value on request

Command BR

<id>BR<param> Release (cancel) KEY secured command
<id>BR Query of the current BR-Parameter
Command echo !xxBRxxxxx

Description: By transmitting the BR command through parameter 0000x the requested baud rate is set.

Parameter description:

Parameter	Description
00002	1200 baud (8n1)
00003	2400 baud (8n1)
00004	4800 baud (8n1)
00005	9600 baud (8n1)
00006	19200 baud (8n1)
00007	38400 baud (8n1)
00008	57600 baud (8n1)

Command TT

<id>TT<param> Automatic Telegram output (ATG) ON/OFF

<id>TT Query of the current TT-Parameter

Command echo !xxTTxxxxx

Description: By transmitting the TT-command through parameter 00001 the automatic telegram output is activated. The WD-telegram for ex. 147.51<CR> is transmitted with the set output interval. The TT-command through parameter 00000 switches off automatically the telegram output.

Parameter description:

Parameter	Description
00000	Automatic telegram output OFF
00001	Automatic telegram output ON

Command OR

<id>OR<param> Set output interval for ATG.

<id>OR Query of the current OR-parameter

Command echo !xxORxxxxx

Description: By transmitting the TT command through parameter xxxxx the output interval is set for the telegram output. The parameter is specified in ms. The interval range is 100ms ... 60000ms.

Parameter description:

Parameter	Description
XXXXX	Interval 100ms 60000

Command ID

<id>DI<param> Set wind transmitter ID

<id>ID Query of the current ID-parameter

Command echo !xxIDxxxxx

Description: By transmitting the ID-command through parameter 000xx the Wind transmitter ID is set. The ID-setting range is 0..98. The ID guarantees the operation of several wind transmitters in one bus system.

Parameter description:

Parameter	Description
000XX	Wind transmitter ID 0.... 98

11 Maintenance

If properly installed, the instrument requires no maintenance. Heavy pollution can lead to blockage of the slot between the rotating and the stable parts of the transmitter. Thus it is advisable to remove the accumulated dirt from the instrument .

Certain symptoms of wear and tear can appear on the ball bearings after years of use. These symptoms are expressed in a lowered sensitivity of response, standstill or run-noises of the ball bearings. In case that such disturbances might occur we recommend to return the instrument - in original package – to the factory for maintenance work.

Remark

For transport of instrument please use original packing.

12 Technical Data

Characteristic	Description
Measuring range	0 ... 360 °
Measuring Accuracy	1°
Resolution of measuring value	0,01° @ 12 Bit serial data stream
Output telegram	xxx.xx z.B. 075.36 °
Measuring time	approx. 6ms / WD-measurement
Survival speed	85 m/s up to 0,5 h
Permissible ambient conditions for operation	-50 ... +80°C all occurring situations of rel. humidity incl. dew moistening
Electrical output	RS 485: 1200; 2400; 4800; 9600; 19200; 38400; 57600 Baud 8 Bit no parity 1Stopbit Seriell RS485: 1.2; 2.4; 4.8; 9.6; 19.2; 38.4; 57. 6; 115.2 KBaud Resolution: 12 bit
Starting threshold	< 0,5 m/s at 10° amplitude
Delay distance	< 1 m (acc. to ASTM D 53666 – 96)
Damping ratio	D > 0,25 (acc. to ASTM D 53666 – 96)
Quality factor	K > 1 $K = \frac{4 \cdot D \cdot \omega_0}{\rho \cdot u}$ D damping ratio, ω_0 angular frequency of undamped oscillation, ρ air density u wind speed.
Heating	Surface temperature of housing neck > 0 °C at 20 m/s up to –10 °C air temperature, at 10 m/s up to –20 °C using the Thies icing standard 012002 on the housing neck heating regulated with temperature sensor
Power supply	Vcc: 3.3 V ... 42 V DC Icc: ca. 6 mA
Electrical supply for heating	Voltage: 24 V AC/DC (galvanically isolated from housing) Power: 25 W

14 Accessories

The following accessories are available for the wind direction transmitter:

Traverse 0,6 m For mounting the wind speed and wind direction transmitter jointly onto a mast	4.3174.00.000	Horizontal sensor distance: 0,6 m Vertical sensor distance: 0,2 m Mast receptacle: 48 - 50 mm Material: Aluminum, anodised Dimensions: tube Ø 34x4mm, 668 mm long, 756 mm high
--	---------------	--

Hanger –FIRST CLASS- 1m For the lateral mounting of a wind speed and wind direction transmitter onto a mast..	4.3184.01.000	Sensor distance to mast: 1 m Mast clamp: 40 – 80 mm Tube diameter: 34 mm Material: Aluminum
---	---------------	--

Lightning rod For mounting the a/m traverse or hanger.	4.3100.98.000	Dimension: Ø 12 mm, 500 mm long, 1050 mm high Material: Aluminum
---	---------------	---

Please contact us for other accessories such as cables, power supply units, masts, as well as for additional mast- or system-constructions.

Example: Wind transmitter with traverse and lightning rod.





ADOLF THIES GmbH & Co. KG

Hauptstraße 76 37083 Göttingen Germany
P.O. Box 3536 + 3541 37025 Göttingen
Phone ++551 79001-0 Fax ++551 79001-65
www.thiesclima.com info@thiesclima.com



- Alterations reserved -