

## Instruction for Use

021414/09/08

---

### ***Wind Direction Transmitter „First Class“***

**4.3150.x0.012 / 110 / 210 / 212**



### **ADOLF THIES GmbH & Co. KG**

Hauptstraße 76                      37083 Göttingen Germany  
Box 3536 + 3541                      37025 Göttingen  
Phone ++551 79001-0              Fax ++551 79001-65  
www.thiesclima.com              info@thiesclima.com

## Contents

1	Models available .....	2
2	Application .....	3
3	Mode of Operation .....	3
4	Recommendation Site Selection / Standard Installation .....	4
5	Installation.....	4
5.1	Mounting of the Wind Vane .....	4
5.2	Electrical Mounting .....	5
5.3	Mechanical Mounting .....	5
5.4	North Alignment.....	6
6	Plug mounting .....	6
7	Maintenance .....	7
8	Connecting Diagram .....	7
9	Technical Data .....	10
10	Dimensional drawing .....	12
11	Accessories .....	13
12	EC-Declaration of Conformity .....	14

## Figures

Figure 1: Mounting of the wind vane .....	5
---	---

## **1 Models available**

Order- No.	Meas. range	Elect. Output	Potentiometer-protective circuit	Power Supply	Heating
4.3150.00.012	0...360°	Potentiometer: 2 kΩ Series resistance: 50 Ω	Yes	4...42 V DC current: ≤ U <sub>s</sub> / 2 kΩ	Yes
4.3150.00.110	0...360°	Potentiometer: 10 kΩ Series resistance : 50 Ω	Yes	4...42 V DC current: ≤ U <sub>s</sub> / 10 kΩ	Yes
4.3150.00.210	0...360°	Potentiometer: 10 kΩ Series resistance : 50 Ω	No	0...30 V DC current: ≤ U <sub>s</sub> / 10 kΩ	Yes
4.3150.00.212	0...360°	Potentiometer: 2 kΩ	No	0...30 V DC current: ≤ U <sub>s</sub> / 2 kΩ	Yes
4.3150.10.012	0...360°	Potentiometer: 2 kΩ Series resistance: 50 Ω	Yes	4...42 V DC current: ≤ U <sub>s</sub> / 2 kΩ	No
4.3150.10.110	0...360°	Potentiometer: 10 kΩ Series resistance: 50 Ω	Yes	4...42 V DC current: ≤ U <sub>s</sub> / 10 kΩ	No
4.3150.10.210	0...360°	Potentiometer: 10 kΩ Series resistance : 50 Ω	No	0...30 V DC current: ≤ U <sub>s</sub> / 10 kΩ	No
4.3150.10.212	0...360°	Potentiometer: 2 kΩ	No	0...30 V DC current: ≤ U <sub>s</sub> / 2 kΩ	No

## 2 Application

---

The wind direction transmitter serves for the detection of the horizontal wind direction in the field of meteorology and the technology of environmental protection.

Special characteristics:

- High level of measuring accuracy and resolution
- High damping ratio at a small delay distance
- Low starting threshold
- Magnetic coupling, which is free of hysteresis and wear, situated between the axis of vane and potentiometer.
- Electronic protective circuit for the limiting of current, and against erroneous connection, with model 4.3150.x0.110 und 4.3150.x0.012
- Easy removal, and mounting when changing the ball bearing

Optional, an electronically-regulated heating system has been installed for winter time use of the wind direction transmitter (see chapter 1, “models available”), in order to prevent the ball-bearing and the external rotation parts from freezing. Power for the heating system could be provided for instance by our Power Supply Unit, order-no. 9.3388.00.000.

---

**Remark:**

*When using fastening adapters (angle, traverses, etc.) please take a possible effect on the measurements by turbulences into consideration.*

---

## 3 Mode of Operation

---

The dynamic characteristics of the wind vane is achieved by the aluminum light-weight construction. The co-action of wind vane and balance weight results in a high damping ratio with small delay distance as excellent characteristic of the complete vane.

The axis of the wind vane is running in ball bearings, and is coupled, in contact less magnetic manner, with the axis of the integrated potentiometer. Thus, clearance and friction in the coupling are avoided, and an easy starting is guaranteed.

An AC- or DC-voltage of 24 V is intended for the separate supply of the optional heating. In all probability, the heating guarantees a trouble-free function of the Wind Direction Transmitter First Class even under extreme meteorological icing-conditions..

The outer parts of the instrument are made of corrosion-resistant anodized aluminum, and stainless steel. Highly effective labyrinth gaskets and O-rings protect the sensitive parts inside the instrument against humidity and dust.

## 4 Recommendation Site Selection / Standard Installation

---

In general wind measurement instruments should be able to detect the wind conditions of a large area. In order to obtain comparable values when determining the surface wind, measurements should be taken at a height of 10 meters over an even area with no obstacles. An area with no obstacles means that the distance between the wind direction transmitter and an obstacle should be at least 10 times the height of the obstacle (s. VDI 3786 Part 2). If it is not possible to fulfill this condition then the wind direction transmitter should be set up a height where local obstacles do not influence the measured values to any significant extent (approx. 6-10 m above the obstacle). The wind direction transmitter should be set up in the center of flat roofs and not on the edge in order to avoid any preferential directions.

## 5 Installation

---

### 5.1 Mounting of the Wind Vane

Before the wind direction transmitter can be installed at a selected site, the wind vane and the balance weight must be mounted at the adaptors of the wind direction transmitter. The individual process steps are explained in the following list, and by the drawing (figure 1). Necessary tool: Philips screw driver.

- **Wind vane:**
  - Remove the screw M3 from the thin adaptor.
  - Put the wind vane onto the thin adaptor. (The longer part of the wind vane deflector must indicate upward).
  - Put the screw M 3 through the hole of the wind vane from below into the adaptor, and screw tight.
- **Balance weight:**
  - Remove the screw M3 from the thicker adaptor.
  - Put the balance weight onto the thicker adaptor.
  - Put the screw M 3 through the hole of the balance weight from below into the adaptor, and screw tight.

---

**Remark:**

*As the screws are covered with locking varnish they are rough-running with the fastening.*

*The screw head must be immersed completely in the counter-bore of balance weight and wind vane!*

---

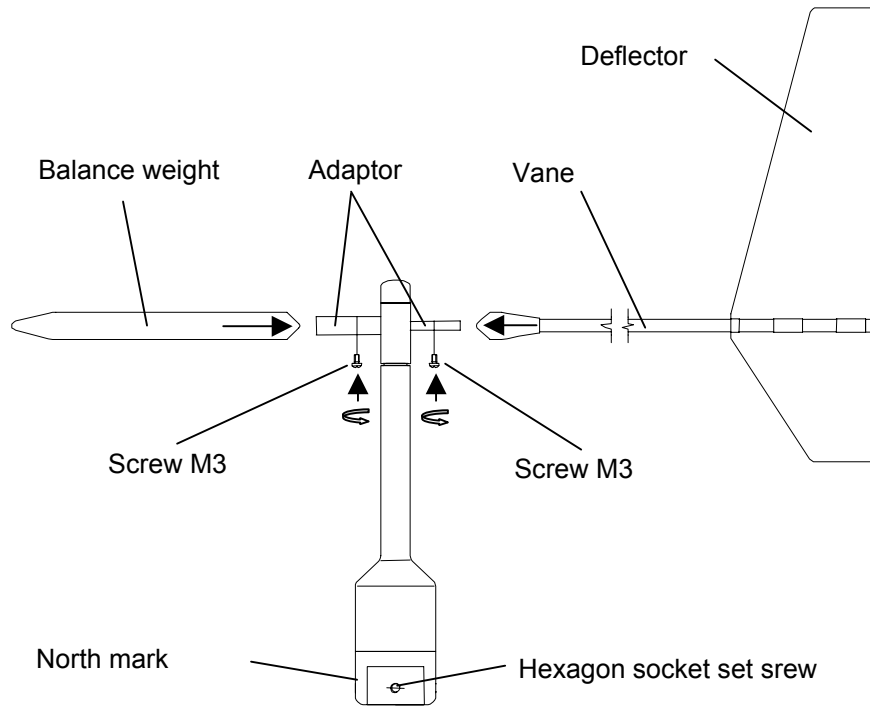

Figure 1: Mounting of the wind vane

## 5.2 Electrical Mounting

Solder a shielded cable with diameter 7-8 mm and a core cross-section of 0,5...0,75 mm<sup>2</sup> to the enclosed coupling socket.

- The number of necessary wires is given in the connection diagram (chapter 8).

Cable recommendation	
Type/ No. of cores /Diameter	Cable diameter
LIYCY 4 x 0,75 mm <sup>2</sup>	ca. 7 mm
LIYCY 5 x 0,50 mm <sup>2</sup>	ca. 7 mm
LIYCY 6 x 0,75 mm <sup>2</sup>	ca. 7,7 mm
LIYCY 7 x 0,50 mm <sup>2</sup>	ca. 7,5 mm
LIYCY 8 x 0,50 mm <sup>2</sup>	ca. 8 mm

## 5.3 Mechanical Mounting

Mount the transmitter onto a pipe socket of R 1" (Ø 33,5 mm) and a length of 25 mm. The pipe socket must have an internal diameter of at least 25 mm as the wind direction transmitter must be connected electrically with a plug from below. After electrical connection the wind direction transmitter is put onto the pipe socket, and is fixed by means of 2 threaded pins (female hexagon 3 mm) at the base of the transmitter.

### **Attention:**

**Storing, mounting and operation under weather conditions is permissible only in vertical position, as otherwise water can get into the instrument.**

## 5.4 North Alignment

**Remark:**

When the wind direction transmitter is in operation, the north marking (line mark) at the base of the transmitter must indicate to the geographical north.

## 6 Plug mounting

Coupling socket 507550 (Binder, Serial 423), EMC with cable clamp	
<ol style="list-style-type: none"> <li>Stringing parts on cable acc. to plan given above.</li> <li>Stripping cable sheath 20 mm Cutting uncovered shield 15 mm Stripping wire 5mm.</li> </ol> <p><i>Cable mounting 1</i> Putting shrink hose or insulating tape between wire and shield.</p> <p><i>Cable mounting 2</i> If cable diameter permits, put the shield backward on the cable sheath.</p> <ol style="list-style-type: none"> <li>Soldering wire to the insert, positioning shield in cable clamp.</li> <li>Screwing-on cable clamp.</li> <li>Assembling remaining parts acc. to upper plan.</li> <li>Tightening pull-relief of cable by screw-wrench (SW16 und 17).</li> </ol>	<p><i>Cable mounting 1</i> View X</p> <p><i>Cable mounting 2</i> View X</p>

## 7 Maintenance

---

If properly installed, the instrument requires no maintenance. Heavy pollution can lead to blockage of the slot between the rotating and the stable parts of the transmitter. Thus it is advisable to remove the accumulated dirt from the instrument .

Certain symptoms of wear and tear can appear on the ball bearings after years of use. These symptoms are expressed in a lowered sensitivity of response, standstill or run-noises of the ball bearings. In case that such disturbances might occur we recommend to return the instrument - in original package – to the factory for maintenance work.

## 8 Connecting Diagram

---

### **Remark**

Models 4.3150.x0.110 / 012 are equipped with electronic protective circuit for current limitation and against erroneous connection.

### **Attention:** Model 4.3150.x0.210 / 212

*When the wind vane rotates over the north point (0 / 360°) the potentiometer slider connects beginning and end of the potentiometer. Therefore, the supply voltage of the potentiometer must show a current limitation of max. 20 mA. When using power supply units temporary current peaks with the power control might lead to damages. Therefore, an additional protective resistance is strongly recommended .*

Order – No.  
 4.3150.00.012  
 4.3150.00.110  
 4.3150.10.012\*  
 4.3150.10.110\*

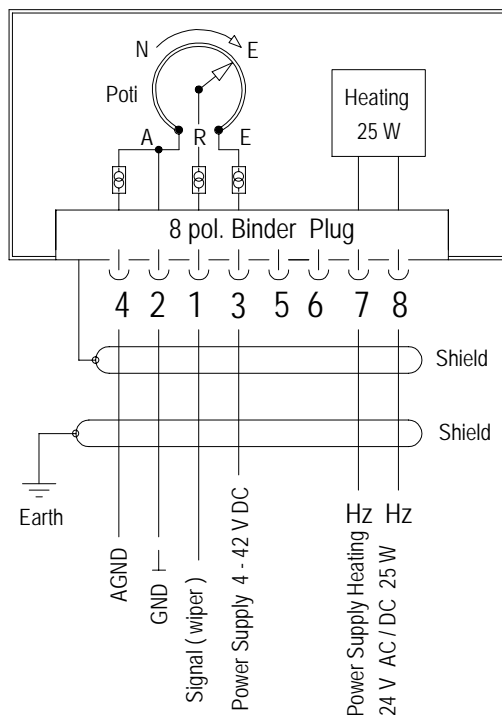

View on the  
 soldered joint  
 of the counter  
 plug

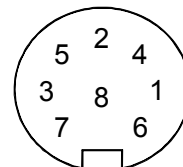

- \*Order-No 4.3150.10.xxx (without heating) contact 7 and 8 is not connected
- With electronic protective circuit for current limitation and against erroneous connection (see Technical Data)

Order – Nr,	Contact	Name	Function
4.3150.00.012 4.3150.00.110 4.3150.10.012* 4.3150.10.110*	1	SIG	Signal (Pot wiper)
	2	GND	Ground
	3	+Us	Supply 4 V...42 V DC
	4	AGND	Analogue ground
	5	NC	Not connected
	6	NC	Not connected
	7	HZ	Heating supply: Voltage: 24 V AC/DC Power: 25 W
	8		
*Order-No 4.3150.10.xxx (without heating) contact 7 and 8 is not connected			



Order – No.  
 4.3150.00.210  
 4.3150.00.212  
 4.3150.10.210\*  
 4.3150.10.212\*

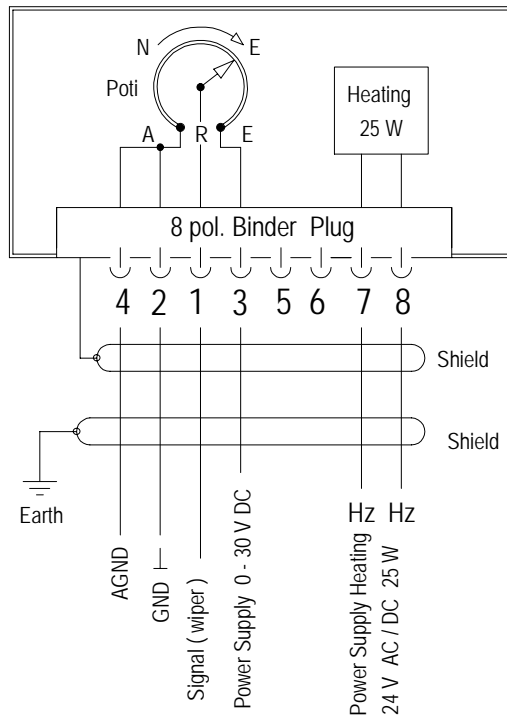

View on the  
 soldered joint  
 of the counter  
 plug

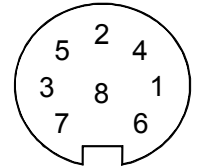

- \*Order-No 4.3150.10.xxx (without heating) contact 7 and 8 is not connected
- Without electronic protective circuit

Order – Nr,	Contact	Name	Function
4.3150.00.210 4.3150.00.212 4.3150.10.210* 4.3150.10.212*	1	SIG	Signal (Pot wiper)
	2	GND	Ground
	3	+Us	Supply 0 V...30 V DC
	4	AGND	Analogue ground
	5	NC	Not connected
	6	NC	Not connected
	7	HZ	Heating supply: Voltage: 24 V AC/DC Power: 25 W
	8		
*Order-No 4.3150.10.xxx (without heating) contact 7 and 8 is not connected			

## 9 Technical Data

Characteristic	Description
Measuring Range	0 ... 360 °
Measuring Accuracy	0,25% (1°)
Survival speed	85 m/s up to 0,5 h (without damages)
Permissible ambient conditions for operation	-50 to +80°C all occurring situations of rel. humidity incl. dew moistening
Electrical output	<p>4.3150.x0.212 2 KΩ Potentiometer</p> <p>4.3150.x0.210 10 KΩ Potentiometer</p>
Electrical output	<p>With electronic protective circuit</p> <p>4.3150.x0.012 Potentiometer (see chapter 1, "models available")</p> <p>4.3150.x0.110 Potentiometer (see chapter 1, "models available")</p> <p>An electronic protective circuit avoids an overloading of the potentiometer in case of erroneous connection, and on transition from 0° to 360 °.</p> <p>The protective circuit represents a nominal series resistance of 50 Ω, however it limits the short-circuit-current on transition from 0° to 360 ° (and vice versa) to ≤ 1 mA at a 10 kΩ Poti and ≤ 2 mA at using a 2 kΩ Poti.</p>
Linearity	0,25% (1°)
Starting threshold	< 0,5 m/s at 10° amplitude
Delay distance	< 1 m (acc. to ASTM D 53666 – 96)
Damping ratio	D > 0,25 (acc. to ASTM D 53666 – 96)
Quality factor	<p>K &gt; 1</p> $K = \frac{4 \cdot D \cdot \omega_0}{\rho \cdot u}$ <p>D           damping ratio,  <math>\omega_0</math>       angular frequency of undamped oscillation,  <math>\rho</math>          air density  u            wind speed</p>
Heating	<p>Surface temperature of housing neck &gt; 0 °C</p> <p>at 20 m/s up to –10 °C air temperature, at 10 m/s up to –20 °C</p> <p>using the Thies icing standard 012002 on the housing neck</p> <p>heating regulated with temperature sensor</p>

Electrical supply for Potentiometer at 4.3150.x0.210 / 212	Voltage $U_s$ : Current:	0V DC ... 30 V DC, <b>Please maintain a supply current of max. 20mA – short circuit at the north point</b> (galvanic isolation from the housing) $\leq$ supply voltage divided by potentiometer resistance
Electrical supply for Potentiometer with electronic protective circuit at 4.3150.x0.012 / 110	Voltage $U_s$ : Current: serial resistance:	4V DC to 42 V DC (galvanic isolation from the housing) $\leq$ supply voltage divided through pot. resistance $\leq$ 1 mA at transition 0 $\rightarrow$ 360° und 360 $\rightarrow$ 0° equipped with 10 k $\Omega$ Potentiometer and $\leq$ 2 mA at transition 0 $\rightarrow$ 360° und 360 $\rightarrow$ 0° equipped with 2 k $\Omega$ Potentiometer 50 $\Omega$ (representative)
Electrical supply for heating	voltage: Capacity:	24V AC/DC (galvanic isolation from the housing) 25 W
Connection	8-pole plug connection for shielded cable in the shaft (see connecting diagram)	
Montage	Mounting on mast 1", for ex. DIN 2441 1½ " with separate adaptor (option)	
Dimensions	See dimensional drawing	
Weight	ca. 0,7 kg	
Protection	IP 55 (DIN 40050)	
EMC	EN 61000-6-2:2001 (immunity) EN 55022:2001, Class B (interfering transmission)	



## 11 Accessories

The following accessories are available for the wind direction transmitter:

Traverse 0,6 m For mounting the wind speed and wind direction transmitter jointly onto a mast	4.3174.00.000	Horizontal sensor distance: 0,6 m Vertical sensor distance: 0,2 m Mast receptacle: 48 - 50 mm Material: Aluminum, anodised Dimensions: tube Ø 34x4mm, 668 mm long, 756 mm high
--	---------------	--

Hanger –FIRST CLASS- 1m For the lateral mounting of a wind speed and wind direction transmitter onto a mast..	4.3184.01.000	Sensor distance to mast: 1 m Mast clamp: 40 – 80 mm Tube diameter: 34 mm Material: Aluminum
---	---------------	--

Lightning rod For mounting the a/m traverse or hanger.	4.3100.98.000	Dimension: Ø 12 mm, 500 mm long, 1050 mm high Material: Aluminum
---	---------------	---

Please contact us for other accessories such as cables, power supply units, masts, as well as for additional mast- or system-constructions.

Example: Wind transmitter with traverse and lightning rod.



# 12 EC-Declaration of Conformity

Document-No.: 001584

Month: 09 Year: 08

Manufacturer: **ADOLF THIES GmbH & Co. KG**

Hauptstr. 76  
D-37083 Göttingen  
Tel.: (0551) 79001-0  
Fax: (0551) 79001-65  
email: Info@ThiesClima.com

Description of Product: **Wind Direction Transmitter FIRST CLASS**

Article No.	<b>4.3150.00.000</b>	<b>4.3150.00.001</b>	<b>4.3150.00.012</b>	<b>4.3150.00.110</b>
	<b>4.3150.00.140</b>	<b>4.3150.00.141</b>	<b>4.3150.00.161</b>	<b>4.3150.00.210</b>
	<b>4.3150.00.212</b>	<b>4.3150.00.400</b>		
	<b>4.3150.10.000</b>	<b>4.3150.10.001</b>	<b>4.3150.10.012</b>	<b>4.3150.10.110</b>
	<b>4.3150.10.140</b>	<b>4.3150.10.141</b>	<b>4.3150.10.161</b>	<b>4.3150.10.210</b>
	<b>4.3150.10.212</b>	<b>4.3150.10.400</b>		

specified technical data in the document: **021413/09/08; 021479/12/06; 021513/10/06; 021516/07/08  
021534/06/07**

The indicated products correspond to the essential requirement of the following European Directives and Regulations:

- 2004/108/EC DIRECTIVE 2004/108/EC OF THE EUROPEAN PARLIAMENT AND OF THE COUNCIL of 15 December 2004 on the approximation of the laws of the Member States relating to electromagnetic compatibility and repealing Directive 89/336/EEC
- 2006/95/EC DIRECTIVE 2006/95/EC OF THE EUROPEAN PARLIAMENT AND OF THE COUNCIL of 12 December 2006 on the harmonisation of the laws of Member States relating to electrical equipment designed for use within certain voltage limits
- 552/2004/EC Regulation (EC) No 552/2004 of the European Parliament and the Council of 10 March 2004 on the interoperability of the European Air Traffic Management network (the interoperability Regulation)

The indicated products comply with the regulations of the directives. This is proved by the compliance with the following standards:

Reference number	Specification
IEC 61000-6-2: 2005	Electromagnetic compatibility Immunity for industrial environment
IEC 61000-6-3: 2006	Electromagnetic compatibility Emission standard for residential, commercial and light industrial environments
IEC 61010-1: 2001	Safety requirements for electrical equipment for measurement, control and laboratory use. Part 1: General requirements

Place: Göttingen

Date: 26.09.2008

Legally binding signature:

issuer:

.....  
Wolfgang Behrens, General Manager

.....  
Joachim Beinhorn, Development Manager

This declaration certifies the compliance with the mentioned directives, however does not include any warranty of characteristics. Please pay attention to the security advises of the provided instructions for use.





## **ADOLF THIES GmbH & Co. KG**

Hauptstraße 76      37083 Göttingen Germany  
P.O. Box 3536 + 3541      37025 Göttingen  
Phone ++551 79001-0      Fax ++551 79001-65  
[www.thiesclima.com](http://www.thiesclima.com)      [info@thiesclima.com](mailto:info@thiesclima.com)



- Alterations reserved -