

Instruction for Use

021434/06/06

Wind Direction Transmitter - compact

- with Poti- Output -
4.3129.xx.712



ADOLF THIES GmbH & Co. KG

Hauptstraße 76

Box 3536 + 3541

Phone ++551 79001-0

www.thiesclima.com

37083 Göttingen Germany

37025 Göttingen

Fax ++551 79001-65

info@thiesclima.com

Contents

1	Models available	2
2	Application	2
3	Construction and Mode of Operation	3
4	Recommendation Side Selection / Standard Installation	3
5	Installation.....	3
5.1	Mechanical Mounting	3
5.2	Electrical Mounting	4
6	Plug Mounting	4
7	Maintenance	4
8	Connecting Diagrams	5
9	Technical Data.....	6
10	Dimensional Drawing.....	6
11	Accessories	7

1 Models available

Order-No.	Meas. range	Electr. Output	Operating Voltage Potentiometer	Heating	Connection
4.3129.00.712	0...360°	Potentiometer: 2 kΩ	0...24 V DC	24V, 20W	7 pol. plug
4.3129.04.712	0...360°	Potentiometer: 2 kΩ	0...24 V DC	24V, 20W	7 pol. plug
4.3129.10.712	0...360°	Potentiometer: 2 kΩ	0...24 V DC	w/o heating	7 pol. plug

2 Application

The wind direction transmitter is designed for the acquisition of the horizontal wind direction. The measuring value is output proportionally to wind direction as analogue voltage in case the potentiometer is supplied by a constant voltage. The measuring data available are ideally adapted to the supply in display instruments, recording instruments, datalogger, as well as process control systems.

For winter time use the instrument is optionally equipped with an electronically regulated heating, in order to guarantee a smooth-running of the ball bearing, and to prevent a blocking of the gap between the external rotation parts by ice aggregation.

Power for the heating system could be provided for instance by our Power Supply Unit, Order No. 9.3388.00.000

3 Construction and Mode of Operation

The outer parts of the instrument are made of corrosion-resistant material (aluminum, stainless steel, plastic). The aluminum parts are additionally protected by means of an anodic coat. Labyrinth sealing protects sensitive parts inside the instrument against humidity.

The wind direction is detected by means of a low-inertia wind vane, the ball bearing axis of which is connected to a potentiometer.

4 Recommendation Side Selection / Standard Installation

In general wind measurement instruments should be able to detect the wind conditions of a large area. In order to obtain comparable values when determining the surface wind, measurements should be taken at a height of 10 meters over an even unobstructed area. An unobstructed area means that the distance between the wind transmitter and an obstacle should be at least 10 times the height of the obstacle (s. VDI 3786). If it is not possible to fulfil this condition, then the wind transmitter should be set up a height where local obstacles do not influence the measured values to any significant extent (approx. 6-10 m above the obstacle).

The wind transmitter should be set up in the centre of flat roofs and not on the roof side in order to avoid bias in the direction (privileged directions).

5 Installation

Attention:

Storing, mounting and operation under weather conditions is permissible only in vertical position, as otherwise water can get into the instrument.

Remark:

When using fastening adapters (angle, traverses, hangers etc.) please take a possible effect by turbulences in their slipstream into consideration.

5.1 Mechanical Mounting

The mounting of the transmitter could be done for example at a traverse with a boring of PG 21 or on hangers with a boring of 29 mm \varnothing . (for ex. traverse *compact*, order-no. 4.3171.30.000). The connection cable or connecting plug is passed through the boring, and the wind direction transmitter is fixed with hexagonal nut (SW36) after the north alignment.

North Alignment

Rotate the case markings (north marking) on the shaft and on the protective cap until they are aligned. Then select an obvious point in a northerly direction in the surroundings (a tree, a building etc.) with the aid of a compass. Take a bearing on this point over the wind vane and the counter weight of the wind direction transmitter, and when these coincide screw the wind transmitter into place. (the north marking must indicate to the geographic north).

5.2 Electrical Mounting

For electrical connection please refer to the connecting diagram.

6 Plug Mounting

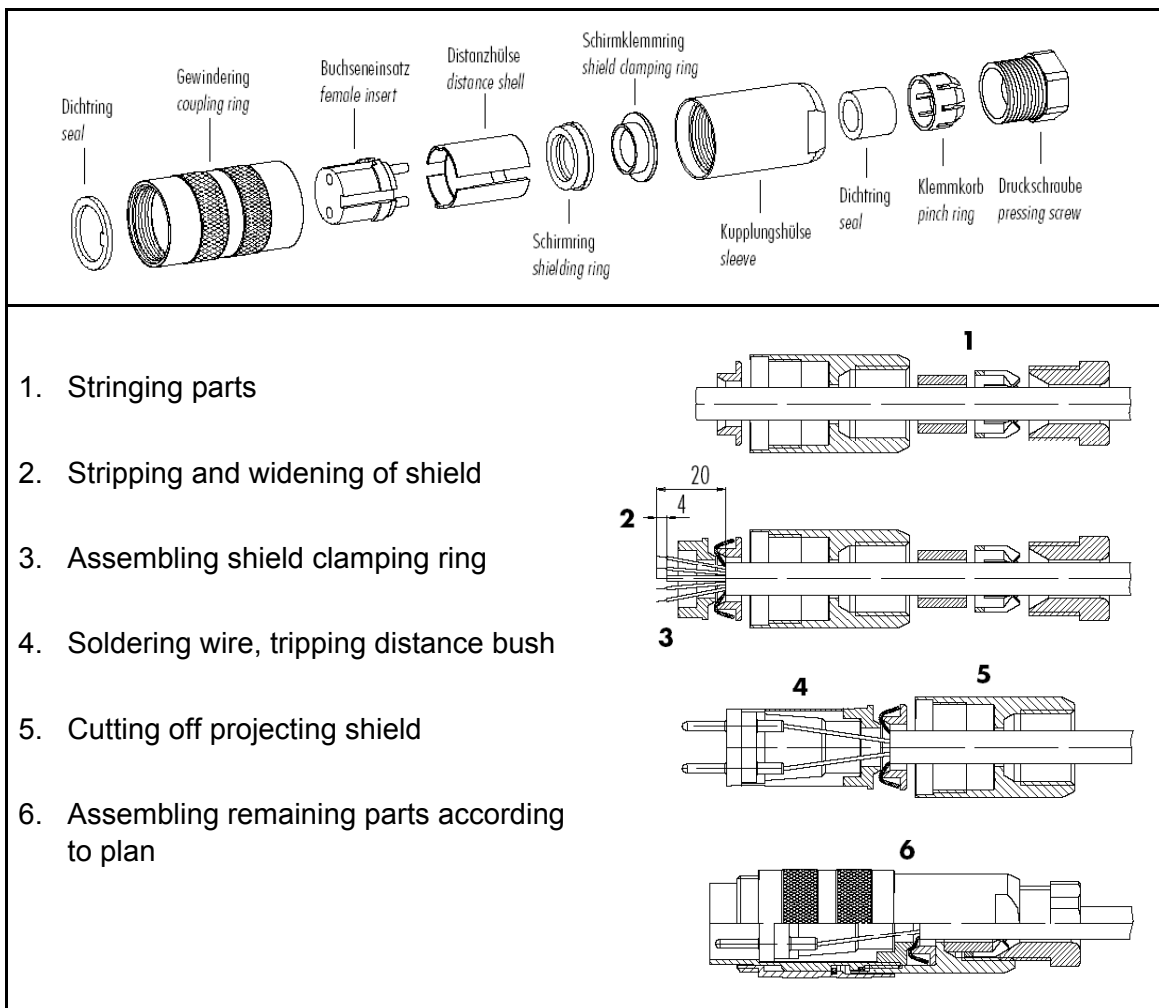

7 Maintenance

After proper mounting the instrument works maintenance free.

Heavy pollution can clog up the slit between the rotating and the stationary parts of the wind transmitter. This slit must be kept clean.

8 Connecting Diagrams

Attention:

When the wind vane rotates over the north point (0 / 360°) the potentiometer slider connects beginning and end of the potentiometer. Therefore, the supply voltage of the potentiometer must show a current limitation of max. 20 mA. When using power supply units temporary current peaks with the power control might lead to damages. Therefore, an additional protective resistance is strongly recommended .

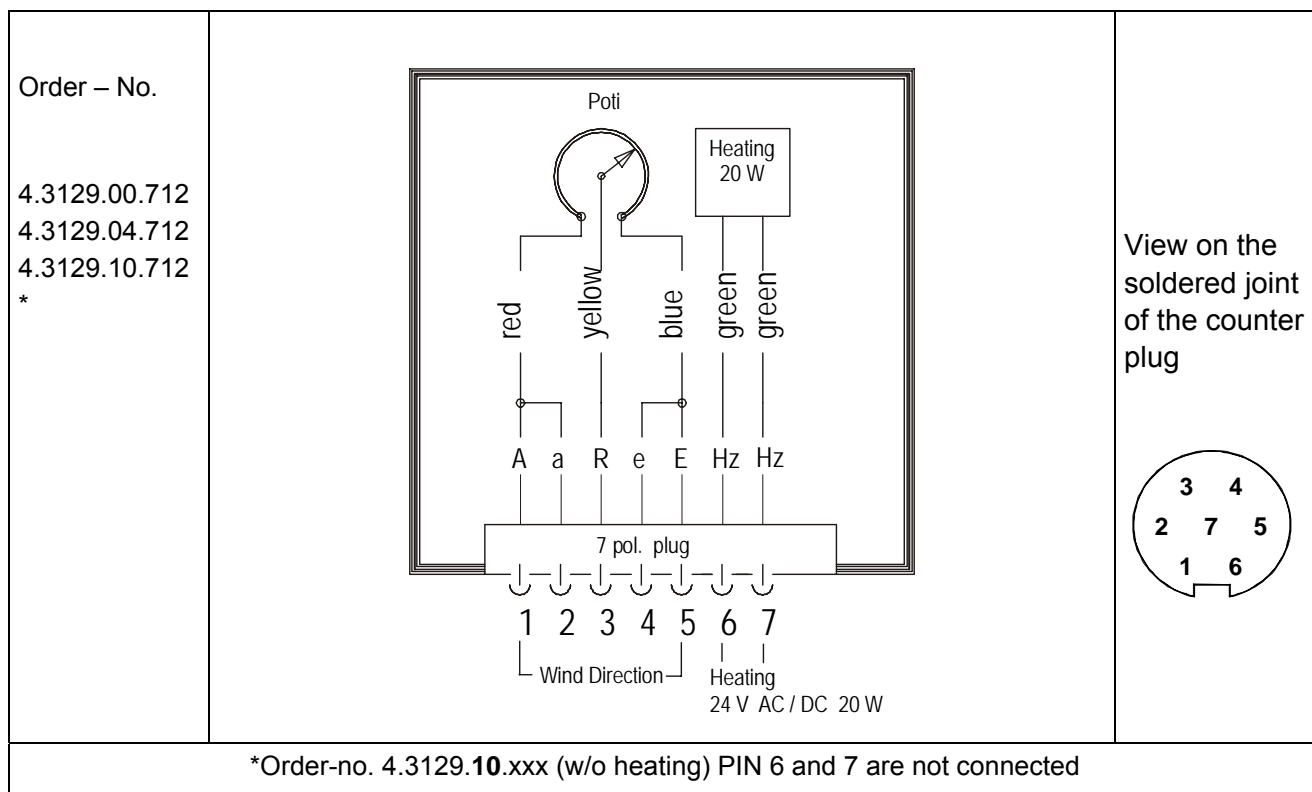

Order – No,	Contact	Name	Function	
4.3129.00.712 4.3129.04.712 4.3129.10.712*	1	A (AGND)	Sense (-)	
	2	a (GND)	Supply voltage (-)	
	3	R (SIG)	Meas. signal (potent. slider)	
	4	e (+Us)	Supply voltage (+) 0 ...24 V DC	
	5	E (Sense)	Sense (+)	
	6	HZG	Heating supply:	
	7		Voltage: 24 V AC/DC	Power: 20 W
<p>** Order-no. 4.3129.10.xxx (w/o heating) PIN 6 and 7 are not connected</p>				

9 Technical Data

Meas. range	0 ... 360° (0 Ohm in the North point)
Resolution	0,5°
Accuracy	± 3°
Measuring principle	Potentiometer
Potentiometer output	2 KOhm
Electrical supply for potentiometer	Voltage U_s : 0V DC ... 24 V DC, The supply must guarantee a current limiting to max. 20mA – short cut at the North point !
Operating voltage heating	24 V DC/AC, max. 20 W
Ambient temperature *	-40°C ... 70°C
Survival speed	maximally 80 m/s, 30 minutes
Connection	7 pol. Stecker
Dimensions	see dimensional drawing
Montage	For ex. onto a mast tube with receptacle thread PG 21 or boring \varnothing 29 mm
Protection	IP 55
Weight	ca. 1,10 kg

* The ambient temperature, stated for wind direction transmitters without heating, is possible only in ice-free condition.

10 Dimensional Drawing

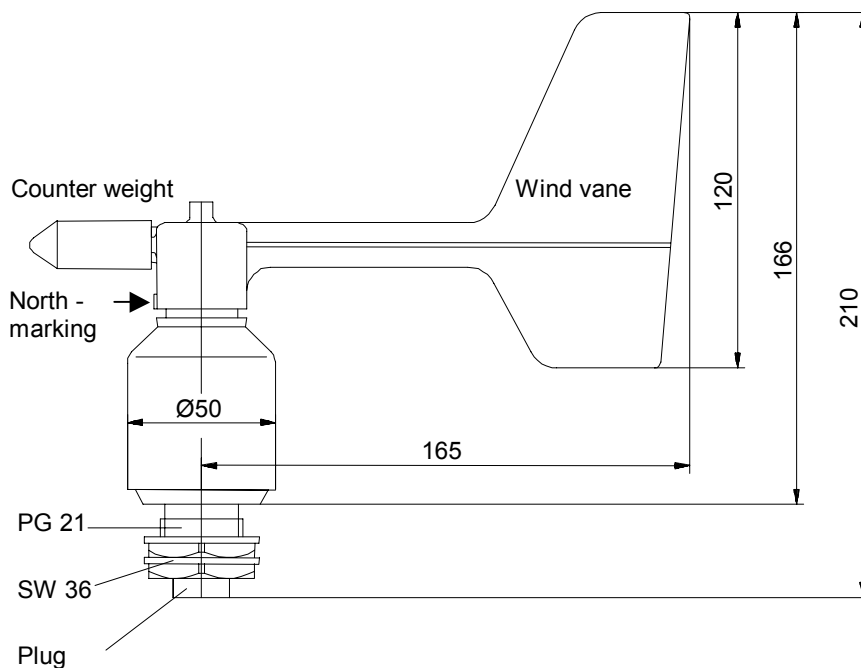

11 Accessories

The following accessories are available for the wind direction transmitter:

<p>Traverse</p> <p>For mounting the wind speed transmitter and wind direction transmitter <i>compact</i> jointly onto a mast.</p>	<p>4.3171.30.000</p> <p>4.3171.31.000</p>	<p>Clamping range: Ø 48 ... 102 mm</p> <p>Clamping range: Ø 116 ... 200 mm</p> <p>Sensor distance: 0,8 m</p> <p>Material: Aluminum</p>
<p>Traverse, short</p> <p>For mounting the wind direction transmitter <i>compact</i> onto a mast.</p>	<p>4.3171.40.000</p> <p>4.3171.41.000</p>	<p>Clamping range: Ø 48 ... 102 mm</p> <p>Clamping range: Ø 116 ... 200 mm</p> <p>Length: 0,4 m</p> <p>Material: Aluminum</p>
<p>Lightning rod</p> <p>For mounting the a.m. traverses</p>	<p>506351</p>	<p>Length: 0,56 m</p> <p>Material: stainless steel</p>

Please contact us for other accessories such as cables, power supply units, masts, as well as for additional mast- or system-constructions.



ADOLF THIES GmbH & Co. KG

Hauptstraße 76 37083 Göttingen Germany
P.O. Box 3536 + 3541 37025 Göttingen
Phone ++551 79001-0 Fax ++551 79001-65
www.thiesclima.com info@thiesclima.com



- Alterations reserved -