

Instruction for Use

021450/11/05

Wind Direction Transmitter - compact

- with serial output -
4.3129.x0.x00



ADOLF THIES GmbH & Co. KG

Hauptstraße 76

Box 3536 + 3541

Phone ++551 79001-0

www.thiesclima.com

37083 Göttingen Germany

37025 Göttingen

Fax ++551 79001-65

info@thiesclima.com

Contents

1	Models available	2
2	Application	3
3	Construction and Mode of Operation	3
4	Recommendation Side Selection/Standard Installation	4
5	Installation.....	4
5.1	Mechanical Mounting	4
5.2	Electrical Mounting	4
6	Plug Mounting	5
7	Maintenance	5
8	Connecting Diagram	6
9	Technical Data.....	7
10	Dimensional Drawing.....	8
11	Accessories	9

Figures

Figure 1: Connecting diagram for models with cable	6
Figure 3 : Interface specification	7
Figure 4: Dimensional drawing with cable.....	8
Figure 5: Dimensional drawing with plug.....	8

1 Models available

Order-No.	Meas. range	Elect. output	Heating capacity	Connection
4.3129.00.000	0 ... 360°	5 bit serial	20 W	12 m cable LiYCY 6 x 0,25 mm ²
4.3129.00.150	0 ... 360°	5 bit serial	20 W	15 m cable LiYCY 6 x 0,25 mm ²
4.3129.00.300	0 ... 360°	5 bit serial	20 W	3,5 m cable LiYCY 6 x 0,25 mm ²
4.3129.00.500	0 ... 360°	5 bit serial	20 W	5,5 m cable LiYCY 6 x 0,25 mm ²
4.3129.00.700	0 ... 360°	5 bit serial	20 W	7 pole plug
4.3129.10.110	0 ... 360°	5 bit serial	w/o heating	10 m cable LiYCY 6 x 0,25 mm ²

2 Application

The wind direction transmitter is designed for the acquisition of the horizontal wind direction. The measuring values are output as electrical digital signals, for example for processing or storing.

An electronically-regulated heating system has been installed optionally for wintertime use, in order to prevent a blocking of the gap between the external rotation parts by ice aggregation.

Power for the heating system could be provided for instance by our Power Supply Unit, Order No. 9.3388.00.000.

3 Construction and Mode of Operation

The outer parts of the instrument are made of corrosion-resistant material (aluminum, stainless steel, plastic). The aluminum parts are additionally protected by means of an anodic coat. Labyrinth sealing protects sensitive parts inside the instrument against humidity.

The wind direction is detected by means of a low-inertia wind vane, the ball bearing axis of which is connected to a code disc. This code disc contains a 5 bit Gray-code which is scanned opto-electronically, and is available at the output in serial form.

The code disc resolves the wind direction into 32 sectors (11,25°/ Sector). The serial output signal is proportional to the 32 sectors.

The sectors start at wind direction N (North) with sector 0, and end with sector n (see drawing).

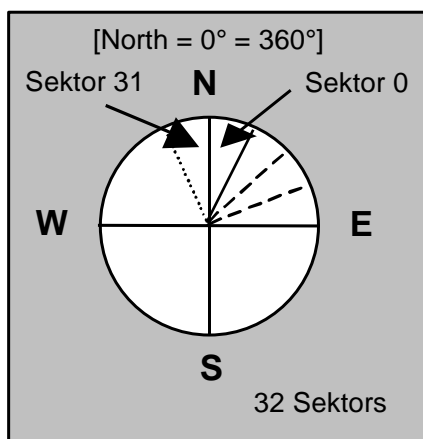

4 Recommendation Side Selection/Standard Installation

In general wind measurement instruments should be able to detect the wind conditions of a large area. In order to obtain comparable values when determining the surface wind, measurements should be taken at a height of 10 meters over an even unobstructed area. An unobstructed area means that the distance between the wind transmitter and an obstacle should be at least 10 times the height of the obstacle (s. VDI 3786). If it is not possible to fulfil this condition, then the wind transmitter should be set up a height where local obstacles do not influence the measured values to any significant extent (approx. 6-10 m above the obstacle).

The wind transmitter should be set up in the centre of flat roofs and not on the roof side in order to avoid bias in the direction (privileged directions).

5 Installation

Attention:

Storing, mounting and operation under weather conditions is permissible only in vertical position, as otherwise water can get into the instrument.

Remark:

When using fastening adapters (angle, traverses, hangers etc.) please take a possible effect by turbulences into consideration.

5.1 Mechanical Mounting

The mounting of the transmitter could be done for example at a traverse with a boring of PG 21 or on hangers with a boring of 29 mm \varnothing . (for ex. traverse *compact*, order-no. 4.3171.30.000). The connection cable or connecting plug is passed through the boring, and the wind direction transmitter is fixed with hexagonal nut (SW36) after the north alignment.

North Alignment

Rotate the case markings (north marking) on the shaft and on the protective cap until they are aligned. Then select an obvious point in a northerly direction in the surroundings (a tree, a building etc.) with the aid of a compass. Take a bearing on this point over the wind vane and the counter weight of the wind direction transmitter, and when these coincide screw the wind transmitter into place. (the north marking must indicate to the geographic north).

5.2 Electrical Mounting

For electrical connection please refer to the connecting diagram.

6 Plug Mounting

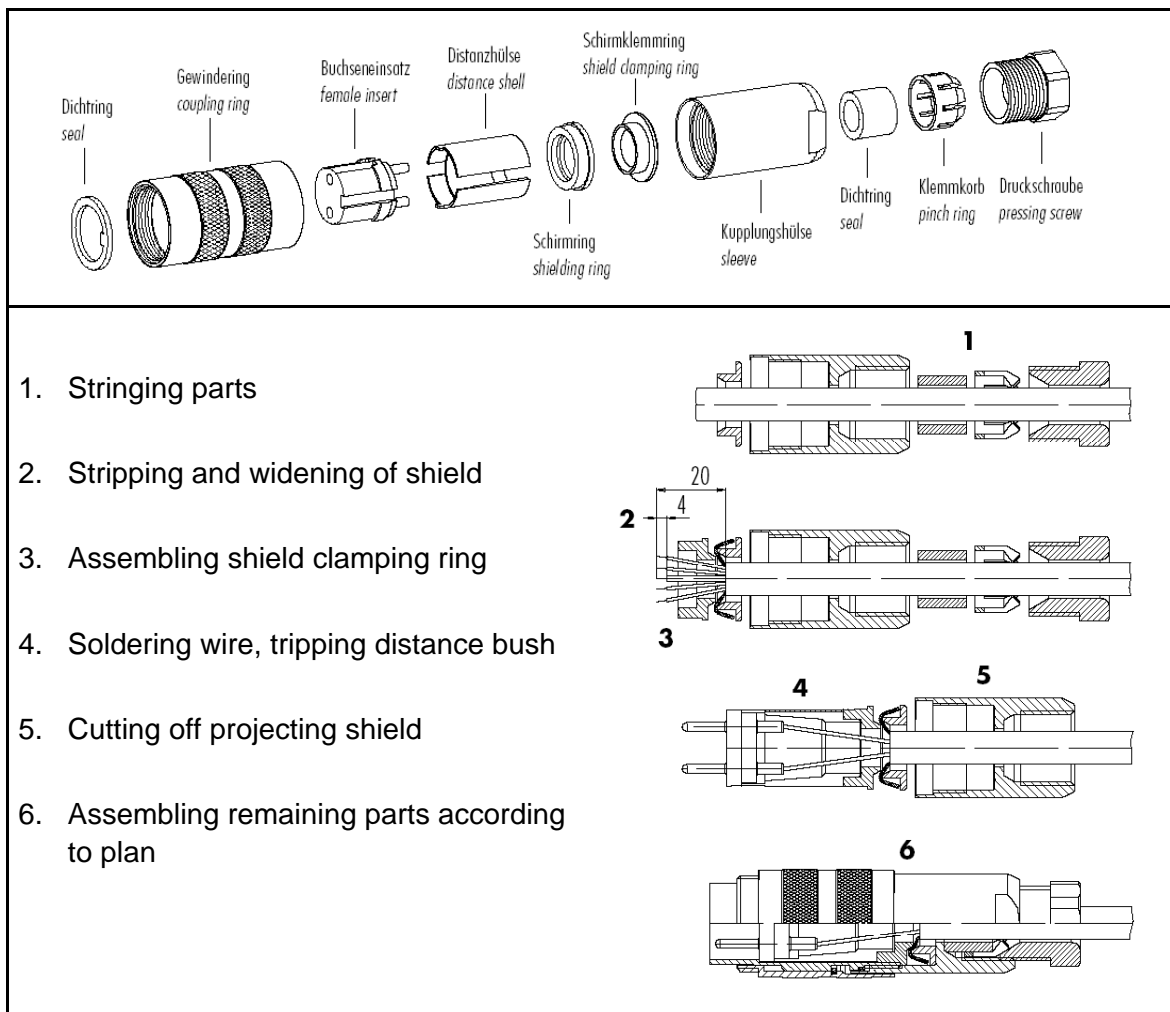

7 Maintenance

After proper mounting the instrument works maintenance free.

Heavy pollution can clog up the slit between the rotating and the stationary parts of the wind transmitter. This slit must be kept clean.

8 Connecting Diagrams

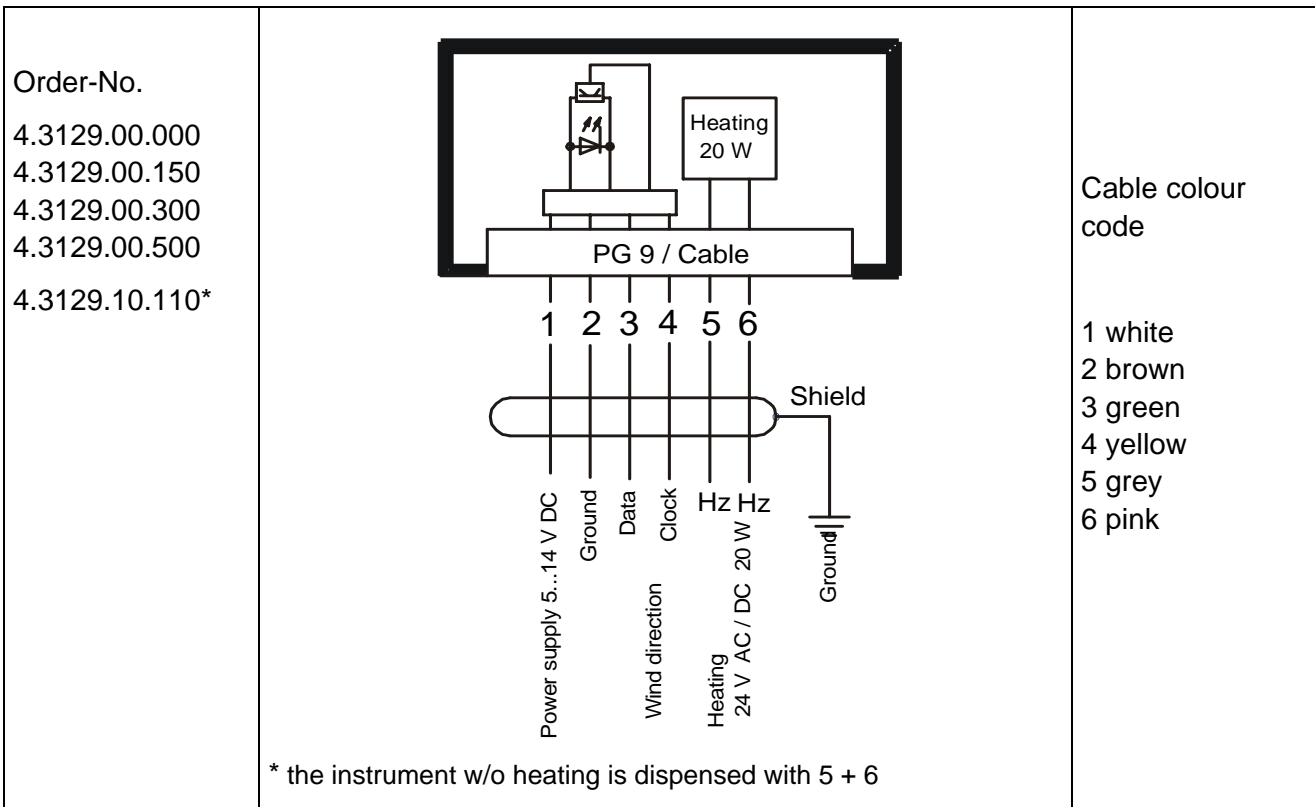

Figure 1: Connecting diagram for models with cable

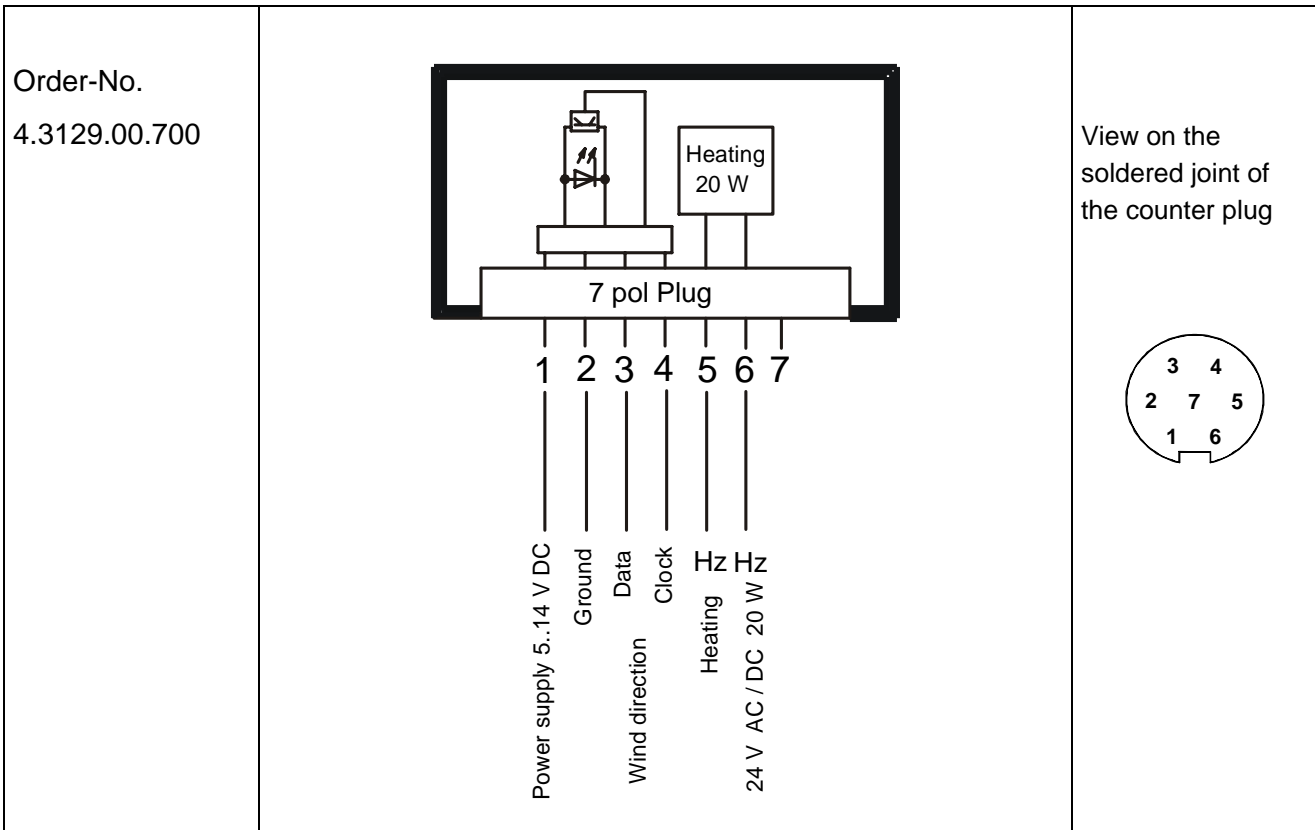

Figure 2: Connecting diagram for models with plug

9 Technical Data

Characteristic	Description / value
Measuring range	0 – 360°
Resolution	11,25
Accuracy	± 5°
Measuring principle	Opto-electronic
Output	5-Bit –Code serial
Electr. output	
Output signal	$U_L = 0 / U_H \approx U_B$ (unloaded)
Load (max.)	10 mA
Serial interface	see interface specification
Operating voltage	5 ... 14 V DC
Current consumption	at $U_B = 5$ V
Standby-operation	< 15 μ A
Active operation	< 500 μ A
Operating voltage heating	24 V DC/AC, max. 20 W
Ambient temperature	- 40 °C ... + 70 °C
Survival speed	maximally 80 m/s, 30 minutes
Connection	See models available
Dimensions	See dimensional drawing
Mounting	For ex. onto a mast tube with receptacle thread PG 21 or boring \varnothing 29 mm
Protection	IP 55
Weight	approx. 0,6 - 1,1 kg

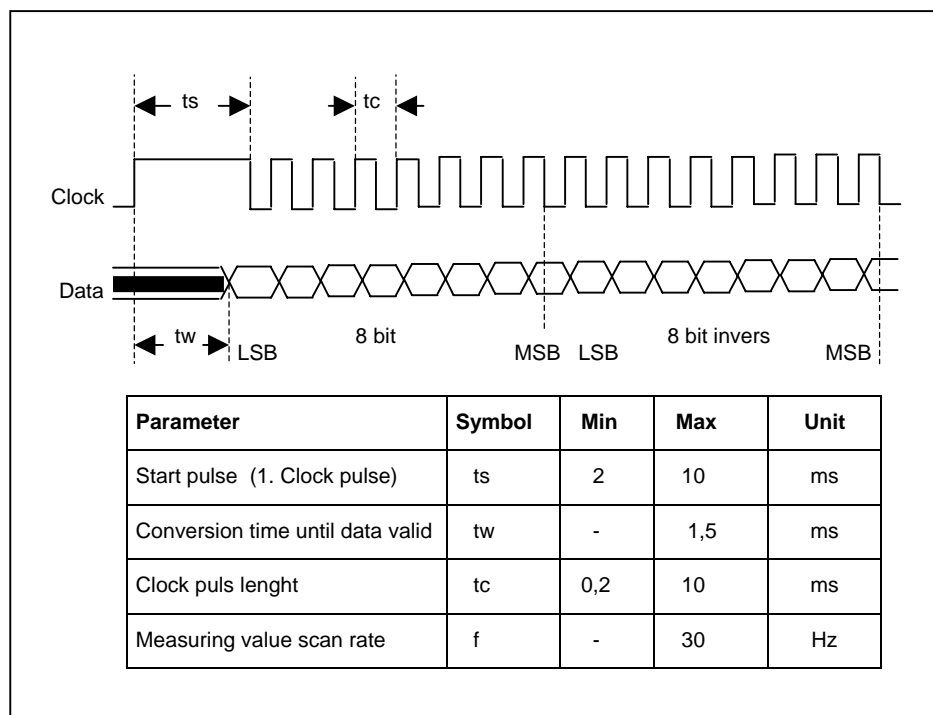

Figure 2 : Interface specification

10 Dimensional Drawing

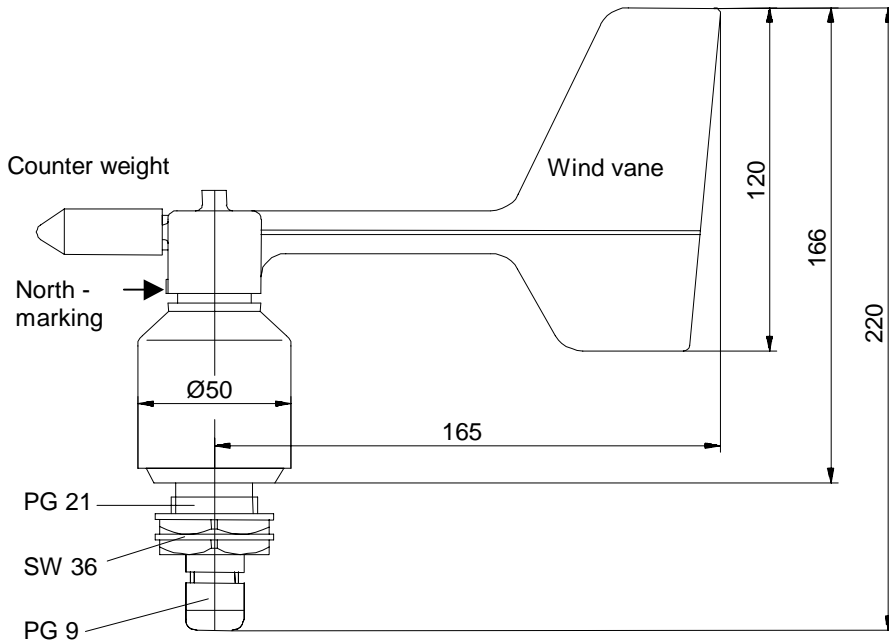

Figure 3: Dimensional drawing with cable

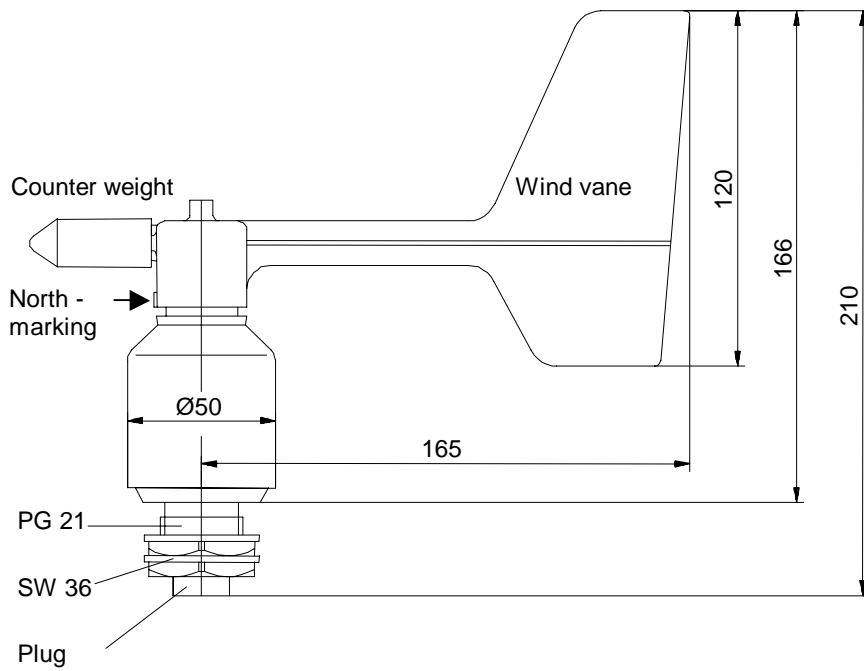

Figure 4: Dimensional drawing with plug

11 Accessories

The following accessories are available for the wind direction transmitter:

Traverse For mounting the wind speed transmitter and wind direction transmitter <i>compact</i> jointly onto a mast.	4.3171.30.000 4.3171.31.000	Clamping range: Ø 48 ... 102 mm Clamping range: Ø 116 ... 200 mm Sensor distance: 0,8 m Material: Aluminum
Traverse, short For mounting the wind direction transmitter <i>compact</i> onto a mast.	4.3171.40.000 4.3171.41.000	Clamping range: Ø 48 ... 102 mm Clamping range: Ø 116 ... 200 mm Length: 0,4 m Material: Aluminum
Lightning rod For mounting the a.m. traverses	506351	Length: 0,56 m Material: stainless steel

Please contact us for other accessories such as cables, power supply units, masts, as well as for additional mast- or system-constructions.



ADOLF THIES GmbH & Co. KG

Hauptstraße 76 37083 Göttingen Germany
P.O. Box 3536 + 3541 37025 Göttingen
Phone ++551 79001-0 Fax ++551 79001-65
www.thiesclima.com info@thiesclima.com



- Alterations reserved -