

## Instruction for Use

020688/11/07

# ***Wind Direction Transmitter***

*- with analogue output*

**4.3125.32.xxx**



### **ADOLF THIES GmbH & Co. KG**

Hauptstraße 76

Box 3536 + 3541

Phone ++551 79001-0

[www.thiesclima.com](http://www.thiesclima.com)

37083 Göttingen Germany

37025 Göttingen

Fax ++551 79001-65

[info@thiesclima.com](mailto:info@thiesclima.com)

## Contents

1	Models .....	2
2	Range of application .....	3
3	Construction and Mode of Operation .....	3
4	Recommendation Site Selection / Standard Installation .....	3
5	Installation.....	4
5.1	Mounting the wind vane .....	4
5.2	Mounting the Wind Direction Transmitter .....	5
5.3	Electrical Mounting .....	6
6	Maintenance .....	7
7	Wiring diagram.....	7
8	Technical Data.....	9
9	Dimensions .....	10
10	EC-Declaration of Conformity .....	11

## Figure

Figure 1: Dimension 4.3125.32.040- 073 .....	10
Figure 2: Dimension 4.3125.32.841 .....	10

## **1 Models**

---

<b>Order-No.</b>	<b>Meas. range WD</b>	<b>Electrical Output</b>	<b>Model</b>
4.3125.32.040	0 ... 360°	0 ... 20 mA Load resistor: ≤ 500 Ω	Standard
4.3325.32.041	0 ... 360°	4 ... 20 mA Load resistor: ≤ 500 Ω	Standard
4.3125.32.060	0 ... 360°	0 ... 1 V Load resistor: ≥ 1000 Ω	Standard
4.3125.32.061	0 ... 360°	0 ... 10 V Load resistor: ≥ 1000 Ω	Standard
4.3125.32.073	0 ... 360°	0 ... 5 V Load resistor: ≥ 1000 Ω	Standard
4.3125.32.841	0 ... 360°	4 ... 20 mA Load resistor: ≤ 500 Ω	“Ship version” * - short wind vane - special ball bearing

\* Wind Direction Transmitters for heavy mechanical load, for ex. on ships, wind power plants or the like.

The wind direction transmitters are shipped in semi-mounted state, in order to avoid transport damages and to keep the package small.

The following parts are included in delivery:

- 1 x wind direction transmitter, pre-mounted
- 1 x cup star
- 1 x wind vane
- 1 x connecting plug

## **2 Range of application**

---

The wind direction transmitter serves for the acquisition of the horizontal components of the wind direction. All measuring values are available at the outputs analogue signals . They can be transmitted to display, recording instruments, dataloggers as well as process control systems.

For winter operation the instruments are equipped with an electronically regulated heating in order to guarantee a smooth running of the ball bearings, and to avoid ice-formation at the slot of the outer rotation parts. The electrical supply of wind transmitter heating is carried out, for ex., by our power supply unit, order-no. 9.3388.00.000.

## **3 Construction and Mode of Operation**

---

The housing, cup star and wind vane are made of aluminum, die the surfaces are anodized. Labyrinth seals and o-rings protect the sensitive internal parts from precipitation. The instrument is designed for mounting to a mast tube; the electrical plug connection is situated in the transmitter shaft.

The light-metal wind vane (in ball bearings) is moved by the wind. The opto-electronic scanning of the direction produces a coded signal, which is transformed into an analogue signal by means of an integrated measuring transducer. Generally, the measuring transducers are supplied by the heating voltage. However, the instrument can be operated also without heating system. In this case, a separate supply voltage is to be connected for the measuring transducer. Outputs and inputs are protected against over-voltage by Transzorb diodes.

## **4 Recommendation Site Selection / Standard Installation**

---

In general, wind measurement instruments should be able to detect wind conditions over a broad range. In order to obtain comparative values of the surface wind, measurements should be taken at a height of 10m above a flat, open terrain. Open terrain means that the distance between the wind transmitter and an obstacle is at least 10 times greater than the height of the obstacle itself. If this requirement cannot be fulfilled, then set the wind transmitter up at a height where the influence of local obstacles on the measured values is minimal (about 6-10 m above the level of the obstacle). If the wind transmitter is set up on a flat roof, then place it in the center of the roof and not at the edge in order to avoid privileged directions.

## 5 Installation

---

### **Attention:**

*Storing, mounting and operation under weather conditions is permissible only in vertical position, as otherwise water can get into the instrument.*

---

### **Remark:**

*When using fastening adapters (angle, traverses, hangers etc.) please take a possible effect by turbulences into consideration.*

---

---

### **Remark:**

*A **Lightning Rod** Order-No. **4.3100.99.000** is recommended if the instrument is to be used in areas with considerable lightning activity.*

---

### 5.1 Mounting the wind vane

Unscrew the cap nut (SW 8) from the case of the Wind Direction Transmitter and remove the disk. The rubber gasket remains in the protection cap. Place the wind vane such that the set pin on the wind vane catches in the notch of the protective cap. Replace the disk and re-screw the cap nut. Make sure you hold the transmitter on the protective cap and not on the wind vane.

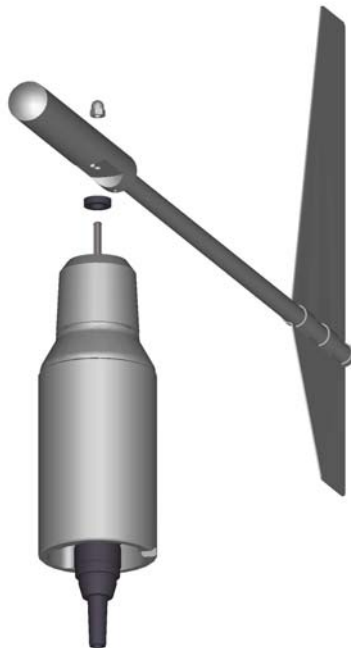

## 5.2 Mounting the Wind Direction Transmitter

The Wind Direction Transmitter can be mounted onto a tube of R 1 1/2" (  $\varnothing$  48,3 mm), 50 mm long. The internal diameter of the mounting tube must be at least 40 mm since the transmitter will be plugged into an electrical system from below. Solder a cable onto the enclosed plug (see chapter 5.4). After electrical connection, set the wind transmitter onto the tube. North marking and bow shall indicate to the North.

### ***North Alignment***

Rotate the case markings (north marking) on the shaft and on the protective cap until they are aligned. Then select an obvious point in a northerly direction in the surroundings ( a tree, a building etc.) with the aid of a compass. Take a bearing on this point over the wind vane and the counter weight of the wind direction transmitter, and when these coincide screw the wind transmitter into place. (the north marking must indicate to the geographic north). The instrument is fixed on the shaft by means of the two hexagon head screws.

### ***Alignment of the comb. Wind Direction Transmitter on a Ship***

- The reference point for the wind transmitter is the roll-axis of the ship, whereat "0°" is related to the **ship bow**.

Rotate the case markings (north marking) on the shaft and on the protective cap until they are aligned. Take a bearing on ship bow over the wind vane and the counter weight of the wind direction transmitter, and when these coincide screw the wind transmitter into place. (the north marking must indicate to the geographic north).

When aligning the comb. wind transmitter on other mobile objects (for ex. vehicles, wind power plants etc.) this procedure can be adopted

### 5.3 Electrical Mounting

A shielded cable with a diameter of 5..8 mm and a core section of 0,5...0,75 mm<sup>2</sup> must be soldered on to the enclosed coupling socket.

The number of required cores, and the PIN assignment is stated in the connection diagram (chapter 7).

Cable recommendation	
Type/ No. of cores /Diameter	Cable diameter
LIYCY 5 x 0,5 mm <sup>2</sup>	approx. 7 mm

Coupling socket 201041 (5-pol), Type Binder, Series 691

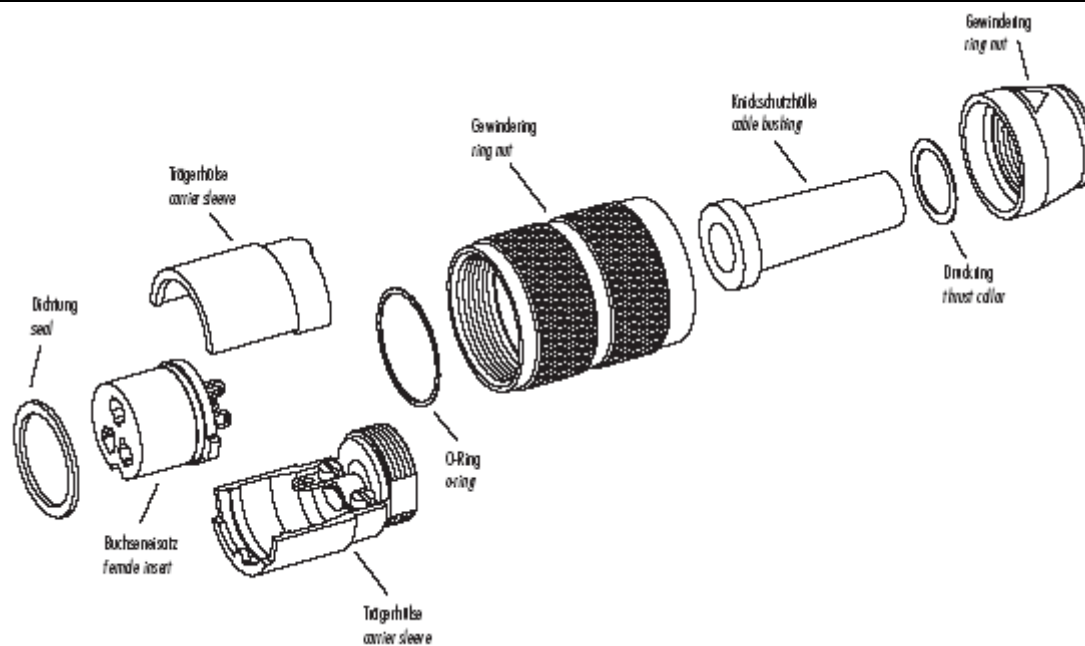

1. Removing Coupling socket
2. Stringing coupling socket on cable
3. Stripping cable sheath 20 mm
4. Putting uncovered shield backwards onto the cable sheath
5. Stripping uncovered cable cores 5 mm
6. Pushing shrink hose over cable cores
7. Soldering stripped cable cores onto the solder filament of the bush insert, pushing shrink hose over the soldering afterwards, and shrinking it.
8. Fastening cable and shield in the carrier sleeve by means of the clamp.
9. Mount coupling socket

## 6 Maintenance

If the instrument has been properly mounted, no maintenance is required. Heavy pollution can clog the slits between the rotating and stationary parts of the instrument. These slits must always be clean and unclogged.

After years of use, the ball bearings can suffer from wear and tear. This is expressed in a higher starting torque respectively in the fact that the Wind Direction Transmitter does not start rotating. If such a defect occurs, we recommend that you return the instrument to the factory for repair.

## 7 Wiring diagram

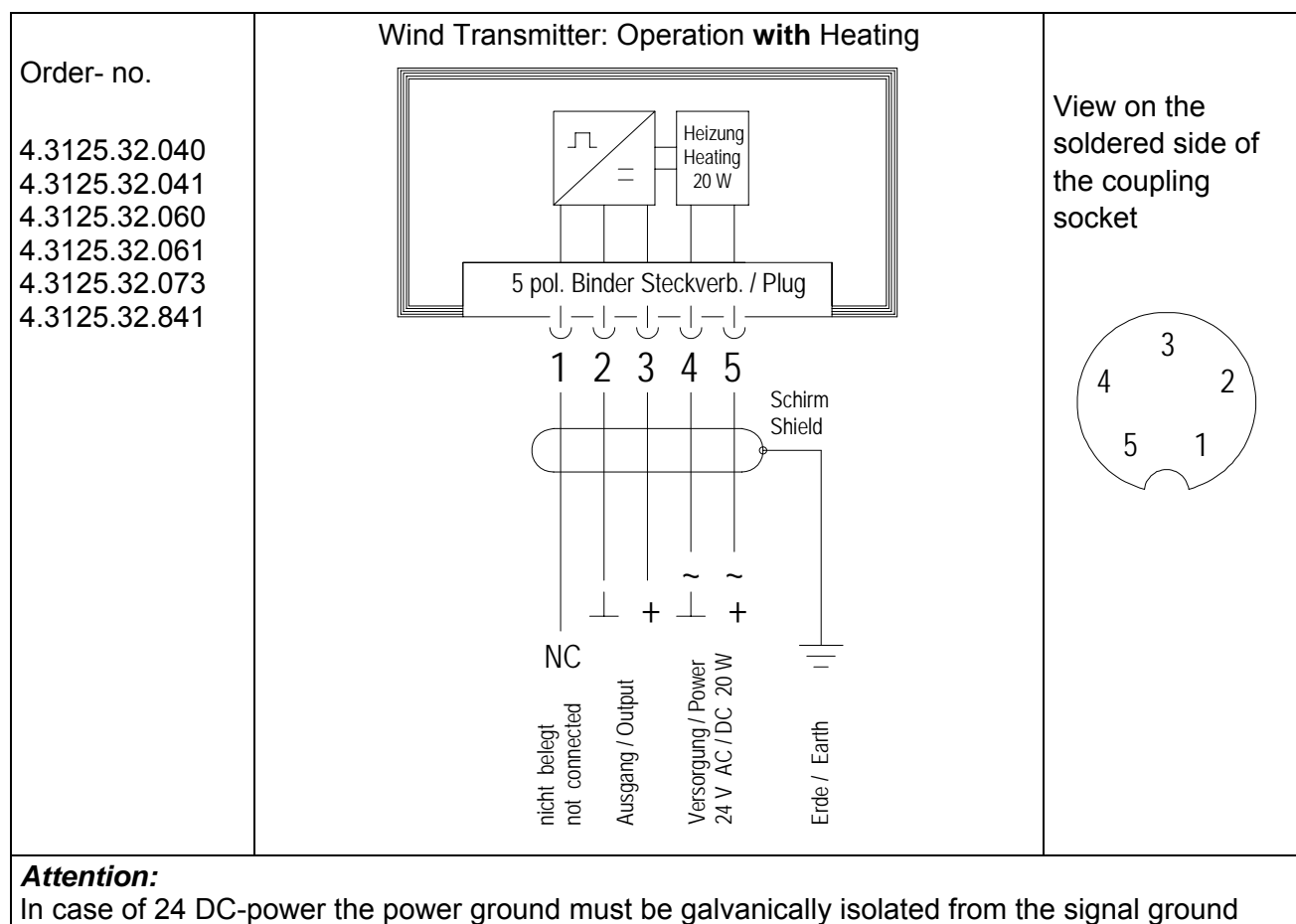

Order no.

4.3125.32.040  
4.3125.32.041  
4.3125.32.060  
4.3125.32.061  
4.3125.32.073  
4.3125.32.841

### Wind Transmitter: Operation **without** Heating

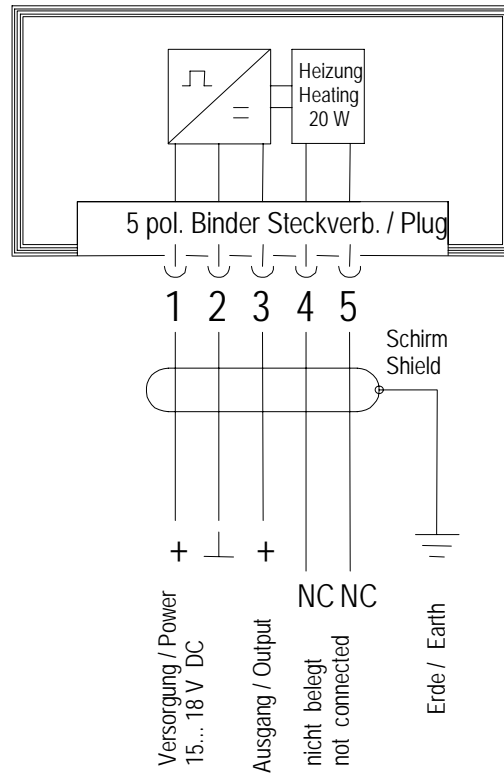

View on the soldered side of the coupling socket

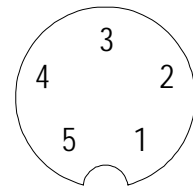

**Attention:**

NC: Cable isolating – no connecting



## 8 Technical Data

	4.3125.32.040 4.3125.32.041 4.3125.32.060 4.3125.32.061 4.3125.32.073	4.3125.32.841
Meas. range	0... 360° (= mA / V )	0... 360° (= 4... 20 mA)
Start-up	<0.6 m/s at 90° vane move	<1 m/s at 90° vane move
Accuracy	2.5°	2.5°
Resolution	2.5°	2.5°
Damping ratio	0.2 –0.3	0.2 –0.3
Electrical outputs	see models available 0/4... 20 mA (Load resistor ≤500 Ω) 0. .. 5 V (Load resistor ≥1000 Ω) 0... 10 V (Load resistor ≥1000 Ω)	4... 20 mA (Lastwiderstand ≤500Ω)
Max. wind load	60 m/s	75 m/s (max. 30 min.)
Ambient temperature	-35...+80°C	-35...+80°C
Operating voltage		
with Heating	24 V DC/AC, approx. 20 W, electronically regulated	24 V DC/AC, approx. 20 W, electronically regulated
without Heating	15 ... 18 V DC	15 ... 18 V DC
Protection	IP 55	IP 55
Wind load at 35 m/s	approx. 50 N	approx. 50 N
Mounting	onto mast tube 1 ½“, for ex. DIN 2441	onto mast tube 1 ½“, for ex. DIN 2441
Connection	5-pole plug connection in the shaft	5-pole plug connection in the shaft
Weight	1.8 kg	1.8 kg
Model	Standard	“Ship version” - short wind vane

## 9 Dimensions

---

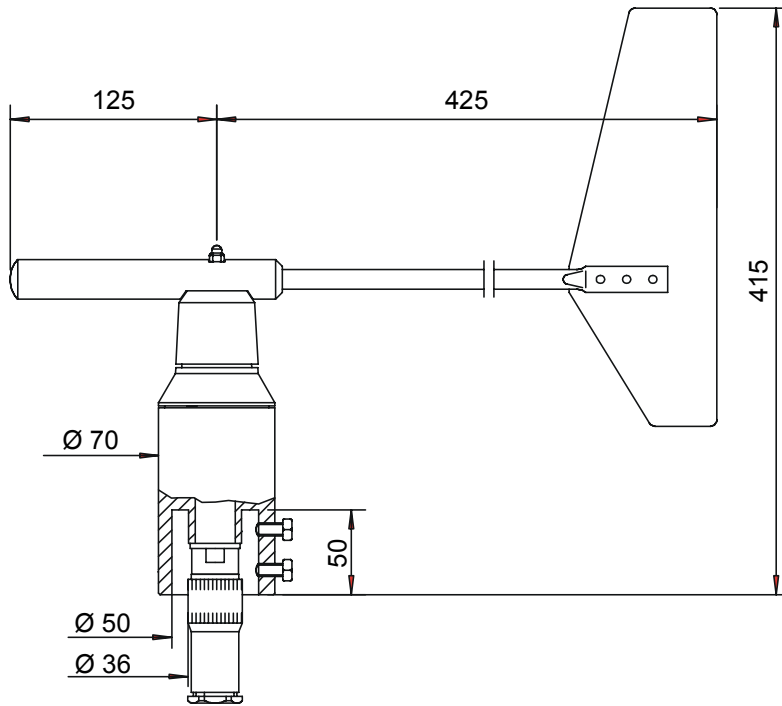

Figure 1: Dimension 4.3125.32.040- 073

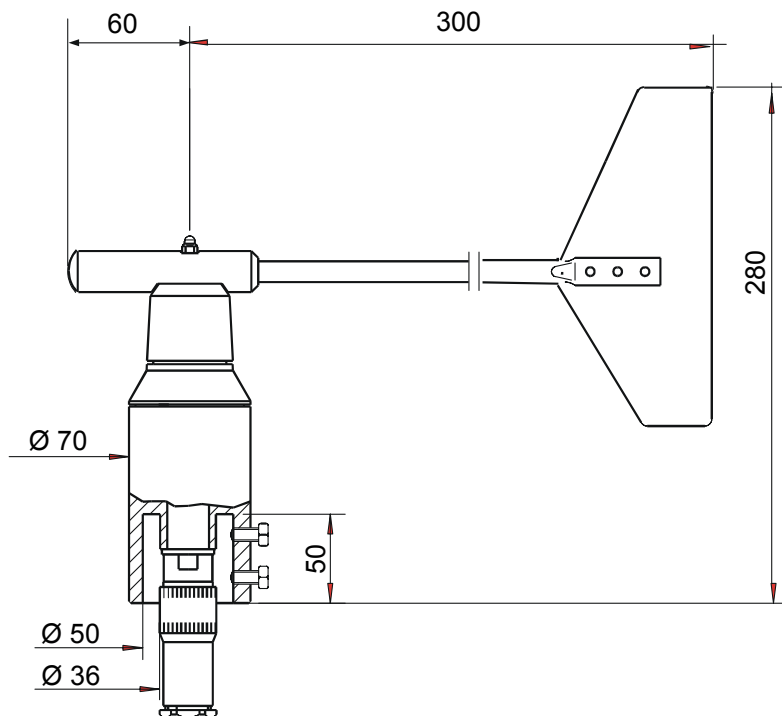

Figure 2: Dimension 4.3125.32.841

# 10 EC-Declaration of Conformity

---

Document-No.: **000434**

Month: 06 Year: 08

Manufacturer: **ADOLF THIES GmbH & Co. KG**

Hauptstr. 76  
D-37083 Göttingen  
Tel.: (0551) 79001-0  
Fax: (0551) 79001-65  
email: Info@ThiesClima.com

Description of Product: **Wind Transmitter, Wind Direction Transmitter, Combined Wind Transmitter**

Article No.	<b>4.3125.32.040</b>	<b>4.3125.32.041</b>	<b>4.3125.32.060</b>	<b>4.3125.32.061</b>
	<b>4.3125.32.073</b>	<b>4.3125.32.841</b>		
	<b>4.3303.22.040</b>	<b>4.3303.22.041</b>	<b>4.3303.22.060</b>	<b>4.3303.22.061</b>
	<b>4.3303.22.073</b>	<b>4.3303.22.640</b>	<b>4.3303.22.641</b>	<b>4.3303.22.660</b>
	<b>4.3303.22.661</b>	<b>4.3303.22.673</b>	<b>4.3303.22.841</b>	
	<b>4.3324.31.040</b>	<b>4.3324.31.041</b>	<b>4.3324.31.061</b>	<b>4.3324.31.073</b>
	<b>4.3324.31.640</b>	<b>4.3324.31.641</b>	<b>4.3324.31.661</b>	<b>4.3324.31.673</b>
	<b>4.3324.31.941</b>			

specified technical data in the docume **020853/10/07; 020854/11/07; 020848/10/07**

The indicated products correspond to the essential requirement of the following European Directives and Regulations:

2004/108/EC	DIRECTIVE 2004/108/EC OF THE EUROPEAN PARLIAMENT AND OF THE COUNCIL of 15 December 2004 on the approximation of the laws of the Member States relating to electromagnetic compatibility and repealing Directive 89/336/EEC
2006/95/EC	DIRECTIVE 2006/95/EC OF THE EUROPEAN PARLIAMENT AND OF THE COUNCIL of 12 December 2006 on the harmonisation of the laws of Member States relating to electrical equipment designed for use within certain voltage limits
552/2004/EC	Regulation (EC) No 552/2004 of the European Parliament and the Council of 10 March 2004 on the interoperability of the European Air Traffic Management network (the interoperability Regulation)

The indicated products comply with the regulations of the directives. This is proved by the compliance with the following standards:

Reference number	Specification
IEC 61000-6-2: 2005	Electromagnetic compatibility Immunity for industrial environment
IEC 61000-6-3: 2006	Electromagnetic compatibility Emission standard for residential, commercial and light industrial environments
IEC 61010-1: 2001	Safety requirements for electrical equipment for measurement, control and laboratory use. Part 1: General requirements

Place: Göttingen

Date: 30.06.2008

Legally binding signature:

issuer:

.....  
Wolfgang Behrens, General Manager

.....  
Joachim Beinhorn, Development Manager

This declaration certifies the compliance with the mentioned directives, however does not include any warranty of characteristics. Please pay attention to the security advises of the provided instructions for use.



## **ADOLF THIES GmbH & Co. KG**

Hauptstraße 76      37083 Göttingen Germany  
P.O. Box 3536 + 3541      37025 Göttingen  
Phone ++551 79001-0      Fax ++551 79001-65  
[www.thiesclima.com](http://www.thiesclima.com)      [info@thiesclima.com](mailto:info@thiesclima.com)



- Alterations reserved -