

Wind Direction Transmitter

Instruction for use 4.3120.xx.000/ .002/ .012/ .018



General Information

Wind transmitters are employed to determine the horizontal wind direction and to convert this into an electrical signal. These signal can be transmitted to display instruments or - with the aid of suitable transducer - to recording instruments.

The instruments are equipped with an electronically regulated heating system for winter use. This heating system prevent the ball-bearing and the external rotating parts from freezing.

Lightning rod, order no. 4.3100.99.000, is recommended when the instrument is to be used in areas with considerable thunderstorm activity.

Delivery condition

The delivery consists of an unassembled wind direction transmitter - in order to reduce the bulk of the package and to avoid transport damage - and the following additional items:

- 1 assemble case
- 1 wind vane
- 1 plug

Models	Order no.	Electr. output	/	max. load
	4.3120.xx.000	3 x 120° ; 2000 $\Omega \pm 5$ %		/ max. 24 V ; max. 1,5 W
	4.3120.xx.002	360° ; 400 $\Omega \pm 1$ %		/ max. 24 V ; max. 1,5 W
	4.3120.xx.012	360° ; 2000 $\Omega \pm 1$ %		/ max. 24 V ; max. 1,5 W
	4.3120.xx.018	358° ; 400 $\Omega \pm 1$ %		/ max. 24 V ; max. 1,5 W
	...10...	without heating		
	...22...	with heating		

Technical data

Measuring range	: 0 ... 360°
Resolution	: 1°
Accuracy	: ..000 / ..002 / ..012 : $\pm 2^\circ$: ..018 : $\pm 3^\circ$
Sensitivity of response	: 0,5 m/s at 90° vane deflection
Damping ratio	: 0,2 – 0,3
Max. wind load	: 60 m/s
Heating voltage	: 24 V AC/DC, ca. 20 W, electronically regulated
Ambient temperature	: - 35 ... + 80°C
Wind load at 35 m/s	: approx. 10 N
Mounting	: onto a mast tube 1 ½", for example DIN 2441
Connection	: 8 pole plug in shaft
Weight	: approx. 1,8 kg

Connecting diagram

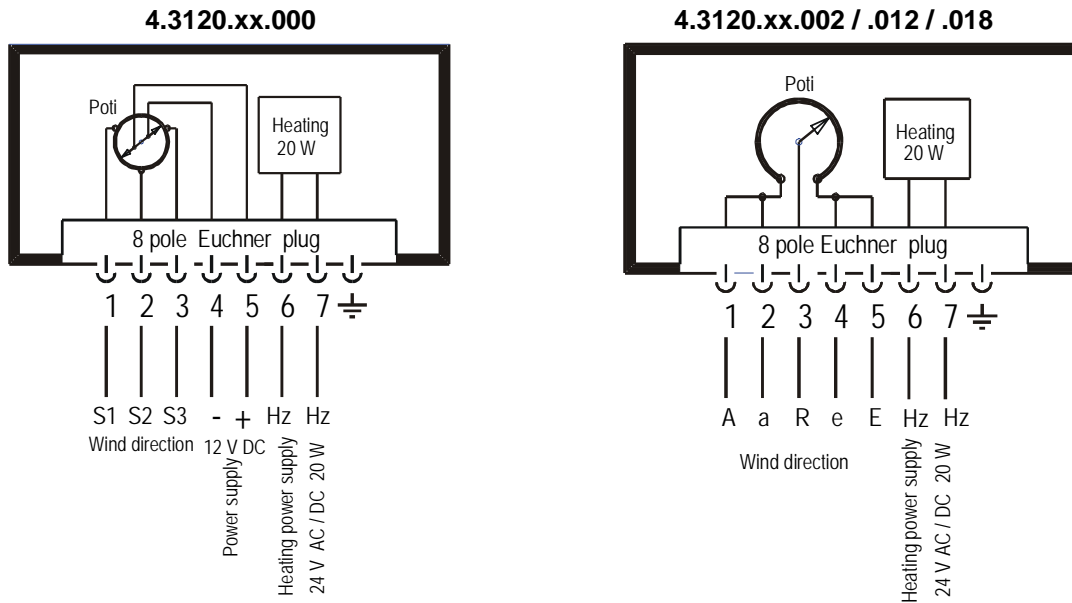

using without heating, Pin 6 + 7 not connected.

Dimension

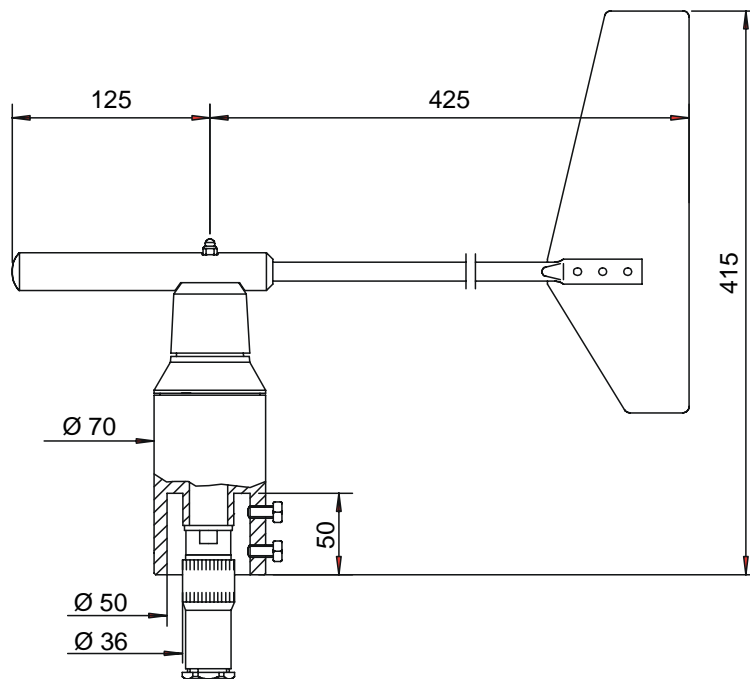

Construction of the instrument

The wind direction is detected by means of a low-inertia light metal vane, whose ball-bearing axle is connected with a potentiometer. According to the position of the vane the resistor value gives the direction signal.

The external parts are made of corrosion-resistant materials and coated with a finish. Labyrinth sealing and o-rings are used to protect the sensitive interior parts from precipitation.

Selecting the measuring site

In general, wind measuring instruments are supposed to record wind conditions over a large area. In order to obtain comparable values for the determination of surface wind, measurements should be made at a height of 10 m above open, level terrain. Open, level terrain is defined as an area where the distance between the wind measuring instrument and an obstruction amounts to at least 10 times the height of the obstruction. If this condition cannot be guaranteed, then the wind measuring instrument should be set up at such a height where the measured values are, to the greatest extent possible, not influenced by local obstructions (approx. 6 - 10 m above the obstruction).

The wind measuring instrument should be installed in the centre of flat roofs - not at the edge - in order to avoid a possible influence in one direction or the other.

Mounting the wind vane

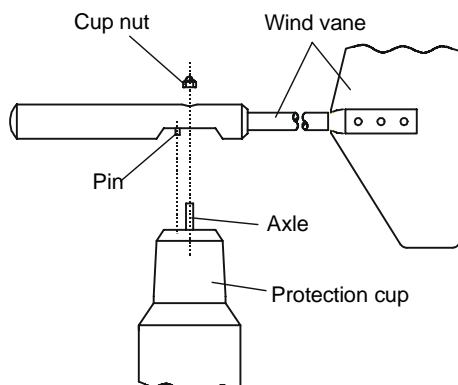

Unscrew the cap nut (SW 8) from the case of the direction transmitter. Keep the rubber sealing ring in the protective cap. Insert the wind vane in such a manner that the dowel pin counterbalances with the nut in the protective cap. Then replace the nut. When doing so, please make sure that you hold the transmitter by the protective cap and not by the wind indicator.

Mounting the wind direction transmitter

The transmitter can be mounted onto a tube of R 1 1/2" (outer diameter \varnothing 48,3 mm), 50 mm long. The internal diameter of the pipe must be at least 40 mm since the transmitter will be plugged into an electrical system at its base.

Solder a flexible control line LiYCY with the required number of leads of 0,5 mm² onto the enclosed plug (see circuit diagram).

Following the electrical connection, set the wind transmitter onto the tube and align it by means of the marking on the case to North. Fasten the instrument onto the shaft with the aid of the 2 hexagonal screws (electrical connection to a display instrument or to a recording instrument should be carried out according to the circuit diagram enclosed with complete system).

Maintenance

If properly installed, the instrument requires no maintenance. Heavy pollution can lead to blockage of the slots between the rotating and the stable parts of the transmitter. Thus it is advisable to remove the accumulated dirt from the instrument periodically.

Certain symptoms of wear and tear can appear on the ball bearings after years of use. These symptoms are expressed in a lowered sensitivity of response on the part of the wind vane. Should such a defect occur, we recommend that you return the instrument to the factory for repair.



ADOLF THIES GmbH & Co. KG

Hauptstraße 76 37083 Göttingen Germany
P.O. Box 3536 + 3541 37025 Göttingen
Phone ++551 79001-0 Fax ++551 79001-65
www.thiesclima.com info@thiesclima.com



- Alterations reserved -